

Kollmorgen Cartridge Direct Drive Rotary[®] Motors Catalog



Cartridge Direct Drive Rotary[®] Motor Series

with AKD[™] Servo Drive Systems

KOLLMORGEN[®]

Because Motion Matters[™]

Kollmorgen. Every solution comes from a real understanding of the challenges facing machine designers and users.

The ever-escalating demands of the marketplace mean increased pressure on machine designers and users at every turn. Time constraints. Demands for better performance. Having to think about the next-generation machine even before the current one is built. While expectations are enormous, budgets are not. Kollmorgen's innovative motion solutions and broad range of quality products help engineers not only overcome these challenges but also build truly differentiated machines.

Because motion matters, it's our focus. Motion can distinctly differentiate a machine and deliver a marketplace advantage by improving its performance. This translates to overall increased efficiency on the factory floor. Perfectly deployed machine motion can make your customer's machine more reliable and efficient, enhance accuracy and improve operator safety. Motion also represents endless possibilities for innovation. We've always understood this potential, and thus have kept motion at our core, relentlessly developing products that offer precision control of speed, accuracy and position in machines that rely on complex motion.

Removing the Barriers of Design, Sourcing, and Time

At Kollmorgen, we know that OEM engineers can achieve a lot more when obstacles aren't in the way. So, we knock them down in three important ways:

Integrating Standard and Custom Products

The optimal solution is often not clear-cut. Our application expertise allows us to modify standard products or develop totally custom solutions across our whole product portfolio so that designs can take flight.

Providing Motion Solutions, Not Just Components

As companies reduce their supplier base and have less engineering manpower, they need a total system supplier with a wide range of integrated solutions. Kollmorgen is in full response mode with complete solutions that combine programming software, engineering services and best-in-class motion components.

Global Footprint

With direct sales, engineering support, manufacturing facilities, and distributors spanning the Americas, Europe, Middle East, and Asia, we're close to OEMs worldwide. Our proximity helps speed delivery and lend support where and when they're needed.

Financial and Operational Stability

Kollmorgen is part of Danaher Corporation. A key driver in the growth of all Danaher divisions is the Danaher Business System, which relies on the principle of "kaizen" – or continuous improvement. Using world-class tools, cross-disciplinary teams of exceptional people evaluate processes and develop plans that result in superior performance.

Table of Contents

- ▶ **AKD™ Servo Drive** 4
- ▶ **Direct Drive Technology** 10
- ▶ **Cartridge Direct Drive Rotary® (DDR) Motor** 12
- Press Feed Machine Application** 15
- System Summary** 16
- C(H)04x, C(H)05x, C(H)06x, C(H)09x, C(H)13x
- Technical Performance Data** 18
- C(H)04x, C(H)05x, C(H)06x, C(H)09x, C(H)13x
- Outline Drawings** 33
- C(H)04x, C(H)05x, C(H)06x, C(H)09x, C(H)13x
- Mounting Requirements** 40
- C(H)04x, C(H)05x, C(H)06x, C(H)09x, C(H)13x
- ▶ **Model Nomenclature** 42
- ▶ **Motioneering® Application Engine** 45

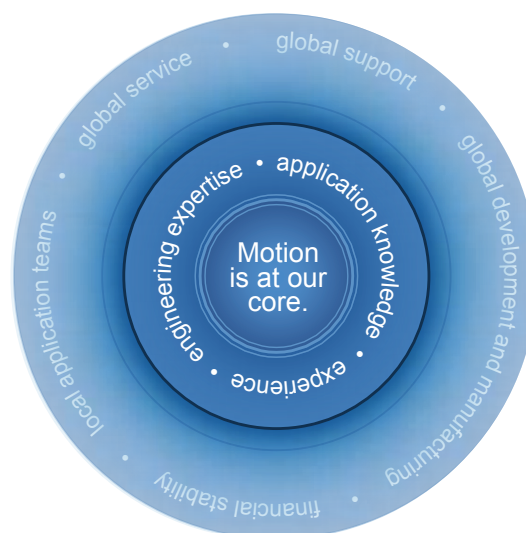

AKD™ Servo Drive

Our AKD series is a complete range of Ethernet-based servo drives that are fast, feature-rich, flexible and integrate quickly and easily into any application. AKD ensures plug-and-play commissioning for instant, seamless access to everything in your machine. And, no matter what your application demands, AKD offers industry-leading servo performance, communication options, and power levels, all in a smaller footprint.

This robust, technologically advanced family of drives delivers optimized performance when paired with our best-in-class components, producing higher quality results at greater speeds and more uptime. With Kollmorgen servo components, we can help you increase your machine's OEE by 50%.

The Benefits of AKD Servo Drive

- | | |
|---|--|
| <ul style="list-style-type: none"> • Optimized Performance in Seconds | <ul style="list-style-type: none"> • Auto-tuning is one of the best and fastest in the industry • Automatically adjusts all gains, including observers • Immediate and adaptive response to dynamic loads • Precise control of all motor types • Compensation for stiff and compliant transmission and couplings |
| <ul style="list-style-type: none"> • Greater Throughput and Accuracy | <ul style="list-style-type: none"> • Up to 27-bit-resolution feedback yields unmatched precision and excellent repeatability • Very fast settling times result from a powerful dual processor system that executes industry-leading and patent pending servo algorithms with high resolution • Advanced servo techniques such as high-order observer and bi-quad filters yield industry-leading machine performance • Highest bandwidth torque-and-velocity loops. Fastest digital current loop in the market |
| <ul style="list-style-type: none"> • Easy-to-use Graphical User Interface (GUI) for Faster Commissioning and Troubleshooting | <ul style="list-style-type: none"> • Six-channel real-time software oscilloscope commissions and diagnoses quickly • Multi-function Bode Plot allows users to quickly evaluate performance • Auto-complete of programmable commands saves looking up parameter names • One-click capture and sharing of program plots and parameter settings allow you to send machine performance data instantly • Widest range of programming options in the industry |
| <ul style="list-style-type: none"> • Flexible and Scalable to Meet any Application | <ul style="list-style-type: none"> • 3 to 24 Arms continuous current; 9 to 48 Arms peak • Very high power density enables an extremely small package • True plug-and-play with all standard Kollmorgen servomotors and actuators • Supports a variety of single and multi-turn feedback devices—Smart Feedback Device (SFD), EnDat2.2, 01, BiSS, analog Sine/Cos encoder, incremental encoder, HIPERFACE®, and resolver • Tightly integrated Ethernet motion buses without the need to add large hardware: EtherCAT®, SynqNet®, Modbus/TCP, EtherNet/IP, PROFINET, and CANopen® • Scalable programmability from base torque-and-velocity through multi-axis master |

AKD Servo Drive

AKD SERVO DRIVE

The AKD servo drive delivers cutting-edge technology and performance with one of the most compact footprints in the industry. These feature-rich drives provide a solution for nearly any application, from basic torque-and-velocity applications, to indexing, to multi-axis programmable motion with embedded Kollmorgen Automation Suite. The versatile AKD sets the standard for power density and performance.



Micron™ Gearheads



AKM™ Servomotors



Kollmorgen Cartridge DDR™ Motors



Housed Direct Drive Rotary Motors



Direct Drive Linear Motors*



Linear Actuators



Multi-Axis Precision Tables

Best-in-Class Components

AKD works seamlessly with Kollmorgen motors and actuators—well-known for quality, reliability, and performance.



AKD™ Servo Drive

AKD Servo Drive Range of Coverage

When you pair the AKD servo drive with any of our Kollmorgen motors or linear positioners, you'll achieve optimized performance. From 3 to 24 Arms continuous current and 9 to 48 Arms peak current, the feature-rich AKD provides a solution for nearly any application.

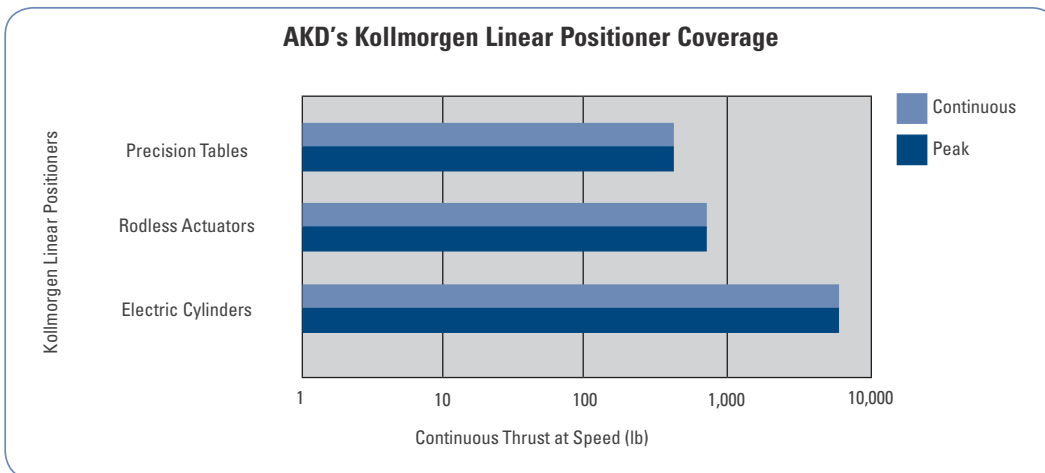
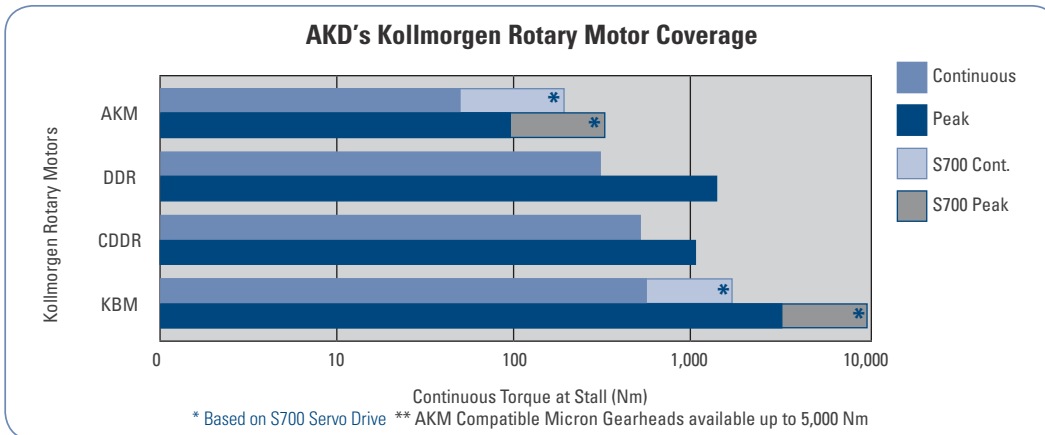
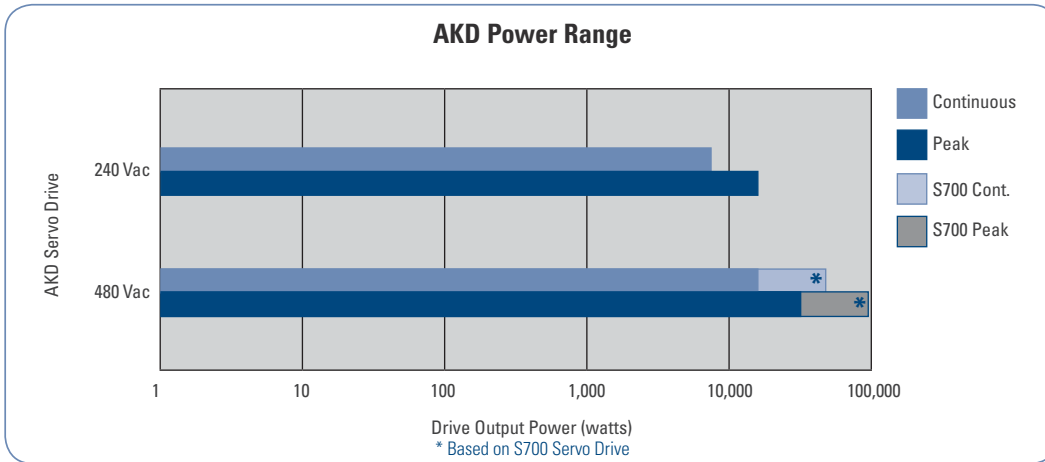

AKD Servo Drive

AKD is specifically designed with the versatility, communications, and power you need to expand machine performance and increase integration speeds. Motor set-up is plug-and-play and multiple Ethernet connectivity options provide both open and closed protocols. Online trouble-shooting and data verification enable faster, bug-proof programming. And a broad power range in a smaller, compact design allows you to use these robust drives with a single interface.

Industry-leading high performance servo loops

Performance Specifications

Servo Loop	Update Rate	Bandwidth (Max)
Current Loop	1.5 MHz, (0.67 μ s)	5.0 kHz
Velocity Loop	16 kHz, (62.5 μ s)	1.6 kHz
Position Loop	8 kHz, (125 μ s)	0.8 kHz

Inputs/Outputs		
Digital Input Events	16 kHz, (62.5 μ s) Update Rate	
Encoder Output or AUX Encoder Input	2.5 MHz Maximum Line Frequency	
Feedback	Smart Feedback Device (SFD), EnDat2.2, 01, BiSS, Analog Sine/Cos encoder, incremental encoder, HIPERFACE®, and resolver	
Logic Supply	24 Vdc	
	Base Drive	With I/O Expansion
Digital Input (24 Vdc)	8 (1 dedicated to enable)	20 (1 dedicated to enable)
Digital Output (24 Vdc)	3 (1 dedicated to fault relay)	13 (1 dedicated to fault relay)
Analog Input (+/- 10 Vdc, 16-bit)	1	2
Analog Output (+/- 10 Vdc, 16-bit)	1	2
Programmable Inputs	7	19
Programmable Outputs	2	12
Sink/Source Inputs/Outputs	Yes	Yes



AKD SERVO DRIVE

Industry-leading power density

General Specifications

120 / 240 Vac 1 & 3 Phase (85 -265 V)	Continuous Current (Arms)	Peak Current (Arms)	Drive Continuous Output Power Capacity (Watts)	Internal Regen		Height mm (in)	Width mm (in)	Depth mm (in)	Depth with Cable Bend Radius mm (in)
				(Watts)	(Ohms)				
AKD-■00306	3	9	1100	0	0	168 (6.61)	57 (2.24)	153 (6.02)	184 (7.24)
AKD-■00606	6	18	2000	0	0	168 (6.61)	57 (2.24)	153 (6.02)	184 (7.24)
AKD-■01206	12	30	4000	100	15	195 (7.68)	76 (2.99)	186 (7.32)	215 (8.46)
AKD-■02406	24	48	8000	200	8	250 (9.84)	100 (3.94)	230 (9.06)	265 (10.43)
240/480 Vac 3 Phase (187-528 V)	Continuous Current (Arms)	Peak Current (Arms)	Drive Continuous Output Power Capacity (Watts)	Internal Regen		Height mm (in)	Width mm (in)	Depth mm (in)	Depth with Cable Bend Radius mm (in)
				(Watts)	(Ohms)				
AKD-■00307	3	9	2000	100	33	256 (10.08)	70 (2.76)	186 (7.32)	221 (8.70)
AKD-■00607	6	18	4000	100	33	256 (10.08)	70 (2.76)	186 (7.32)	221 (8.70)
AKD-■01207	12	30	8000	100	33	256 (10.08)	70 (2.76)	186 (7.32)	221 (8.70)
AKD-■02407	24	48	16,000	200	23	310 (12.20)	105 (4.13)	229 (9.02)	264 (10.39)
S748	48	96	35,000	—	—	385 (15.16)	190 (7.48)	244 (9.61)	285 (11.22)
S772	72	140	50,000	—	—	385 (15.16)	190 (7.48)	244 (9.61)	285 (11.22)

Note: For complete AKD and S700 model nomenclature, refer to pages 43 and 44.

Direct Drive Technology (DDT)

DIRECT DRIVE TECHNOLOGY

Conventional servo systems commonly have a mechanical transmission which can consist of gears, gearheads, belts/pulleys or cams connected between the motor and the load.

With Direct Drive Technology, the mechanical transmission is eliminated and the motor is coupled directly to the load.

Why Use Direct Drive Technology?

Increased Accuracy and Repeatability

A "precision" planetary gearhead could have a backlash of 1 arc-minute. This can result in the load moving by 1 arc-minute with an absolutely stationary drive motor. Kollmorgen's standard direct drive rotary (DDR) servomotors have repeatability better than 1 arc-second. Therefore, a direct drive motor can hold a position 60 times better than a conventional motor/gearhead.

The increased accuracy of direct drive technology results in a higher quality product out of the machine:

- Print registration is more accurate
- Cut or feed lengths can be held more precisely
- Coordination with other machine axes is more accurate
- Indexing location is more exact
- Tuning issues due to backlash are eliminated

Higher Bandwidth

Mechanical transmission components impose a limit on how fast a machine can start and stop and also extend the required settling time. These factors limit the possible throughput of a machine.

Direct drive technology removes these limitations and allows for much faster start/stop cycles and also provides greatly reduced settling time. This will allow a greater throughput from the machine. Users of direct drive systems have reported up to a 2X increase in throughput.

Improved Reliability and Zero Maintenance

Gears, belts, and other mechanical transmission parts break. By eliminating these parts and using DDR motors, the reliability of the machine is improved. Gearheads require periodic lubrication and/or replacement in aggressive start/stop applications. Belts require periodic tightening. There are no time-wear components in a direct drive motor and consequently they require zero maintenance.

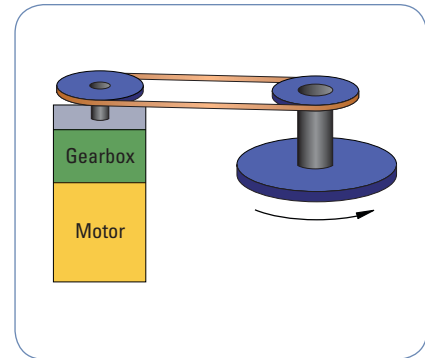

Servomotor and Gearhead



Direct Drive Motor

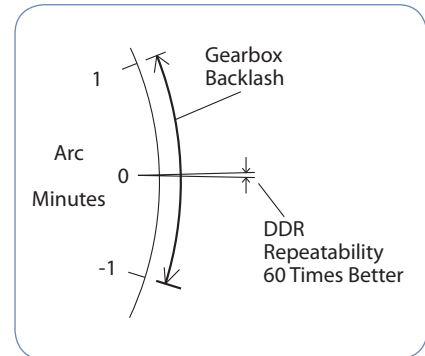

Improved Repeatability

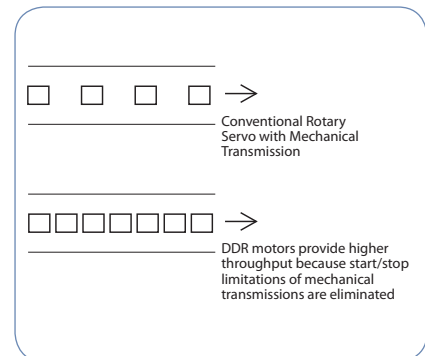

Increased Throughput

Fewer Parts

With direct drive motors, all you need is the motor and the mounting bolts. This often replaces many parts including brackets, guards, belts, pulleys, tensioners, couplings, and bolts, resulting in:

- Fewer parts on the BOM. Less parts to purchase, schedule, inventory and control, and less parts to assemble.
- Assembly time of the servo drops from several hours with the mechanical transmission to several minutes with the DDR.
- Reduced cost. Although a direct drive motor may carry a small price-premium compared to a motor/gearhead with the same torque, consider that there is an overall cost reduction when eliminating the parts and labor of all the extra components required in a servo system with mechanical transmission.

No Inertia Matching

Servo systems with mechanical transmissions require inertia matching that limits the reflected load inertia at 5 to 10 times the motor inertia. If this limitation is not met, the system becomes difficult to control due to instability issues. Inertia matching limitations of mechanical transmission systems often force machine designers to use a larger motor than would otherwise be required just to satisfy the inertia matching requirement.

Such sizing conventions are not required with direct drive technology. Since the motor is directly connected to the load, the inertia of the motor and the load become a common inertia. Therefore, no inertia matching is required when using DDR. DDR applications have run with inertia ratios greater than 11,000:1.

Reduced Audible Noise

Machines with DDR motors have audible noise levels as low as 20 dB less than the same machine with a mechanical transmission.

Direct Drive Linear (DDL) Motor

Directly coupling a linear motor to the driven load offers many advantages, including eliminating all mechanical transmissions, such as ball/lead screws, rack & pinions, belts/pulleys, and eliminating gearboxes. This in turn also eliminates backlash and compliance, and other problems associated with these mechanical transmissions.

DDL Applications

Format	Where Used
Ironless (IL) Series	Applications requiring zero cogging or high acceleration of low mass loads
Ironcore (IC or ICD) Series	Applications requiring highest thrust forces for their size
Water-cooled (IC) Series	Applications requiring the highest possible force

Three DDR Product Categories to Choose From

Kollmorgen's 50 years of electromagnetic and electromechanical design experience combined with our quality and service, allowed us to refine and expand DDR technology into three product categories for easy installation, use, and short lead times: Frameless DDR, Housed DDR, and the Cartridge DDR. This allows you to select the right DDR solution for your application.

KBM Series Frameless DDR

Frameless motors include a rotor and stator as separate components which are integrated into, ride on the bearings of, and become a part of the driven load. Frameless motors offer the most compact and lightweight DDR solution available. The "F" series is Kollmorgen's latest Frameless DDR product. It provides excellent torque/volume with the use of a proprietary neodymium-iron magnet rotor structure and skewed armature assembly. The F series is the first UL recognized parts set available on the market. This provides OEMs with the benefits of UL component ratings for easier agency approval on their machines.

Housed DDR

The Housed DDR is a housed motor assembly featuring a factory aligned high-resolution feedback device and precision bearings, allowing it to function as the core of rotary indexing and rate table applications. The system can also be used as a flexible indexer, providing programmable, rapid indexing far exceeding the throughput and accuracy of conventional mechanical or variable reluctance technology indexers.

Cartridge DDR

This motor is the first in the industry to combine the space-saving and performance advantages of Frameless DDR technology with the ease of installation of a full-frame motor. Consisting of a rotor, stator, and factory-aligned high-resolution feedback device, the motor uses the machine's bearings to support the rotor. An innovative compression coupling engages the rotor to the load and the frame of the motor mounts to the machine with a bolt circle and pilot diameter just like a conventional servomotor, saving space and design time and simplifying the overall system.

DDR Applications

Format	Where Used
Frameless DDR	Application where size and weight must be absolutely minimized
Housed DDR	Applications where the load rides on the motor's bearings such as indexing or rate tables
Cartridge DDR	Any application with existing bearings

Cartridge Direct Drive Rotary (DDR) Motor

The Cartridge DDR Motor is the first in the industry to combine the space-saving and performance advantages of frameless DDR technology with the ease of installation of a full-frame motor. Cartridge DDR motors also feature an advanced electromagnetic design that provides up to 50% more torque density than comparably sized conventional servomotors.

Consisting of a rotor, stator, factory-aligned high-resolution feedback device, the Cartridge DDR motor uses the machine's bearings to support the rotor. An innovative compression coupling secures the Cartridge DDR's rotor to the machine shaft, and the Cartridge DDR's housing is bolted to the machine frame with a bolt circle and pilot – just like a conventional servomotor. Also, mechanical transmission components are eliminated, saving space and design time while simplifying the overall system.

Features

Benefits

- | | |
|--|---|
| <ul style="list-style-type: none"> • Integrated compression coupling and shipping hardware | <ul style="list-style-type: none"> • Eliminate parts and labor for a faster and lower cost machine build |
| <ul style="list-style-type: none"> • 5 frame sizes, multiple lengths • 230 / 400 / 480 Vac windings available (high and low) • Continuous torque range: 4.57 N-m (3.37 lb-ft) to 510 N-m (373 lb-ft) • Speeds up to 2,500 RPM • Optimized torque output with high-pole count efficient electromagnetic design • Hollow shaft available on C09x and C13x models, provides a 1.26 inch (32 mm) through bore to allow process or wiring to run through the center of the motor. Provision for mounting a rotary union to the shaft and housing is included. | <ul style="list-style-type: none"> • Assembles in 5 minutes • Satisfies a wide range of machine requirements and configurations |
| <ul style="list-style-type: none"> • Integrated high-resolution sine encoder • 134,217,728 counts / rev • Low cogging for smooth low-speed rotation • Zero backlash and compliance | <ul style="list-style-type: none"> • Increased accuracy and higher throughput |
| <ul style="list-style-type: none"> • Direct load connection eliminates gearheads, belts, or pulleys | <ul style="list-style-type: none"> • Greater machine reliability and reduced maintenance • Reduced audible noise, fewer parts and lower cost of ownership • More compact machine and reduced design time |

Cartridge DDR Motor

CARTRIDGE DDR MOTOR

Cartridge DDR Application Considerations

Inertia Matching

Since the Cartridge DDR motor is directly connected to the machine, inertial matching is not required as it is on a conventional motor. With direct drive, inertia miss match of 250 to 1 is common and miss match of 1000 to 1 has been demonstrated.

Mounting Orientation

The Cartridge DDR motor can be mounted with any orientation including either a horizontal or vertical shaft.



Mounting Cartridge DDR to Machine

Simple and quick procedures to mount:

- Slide the Cartridge DDR motor onto machine shaft
- Bolt Cartridge DDR motor housing to machine frame
- Torque compression coupling
- Remove/store shipping hardware
- Connect cables and run the motor

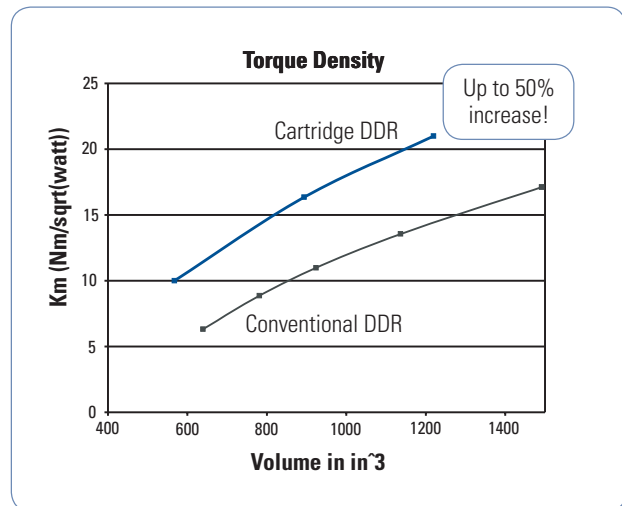

Proprietary electromagnetic design gives Cartridge DDR motors more torque per volume than conventional DDR technology.

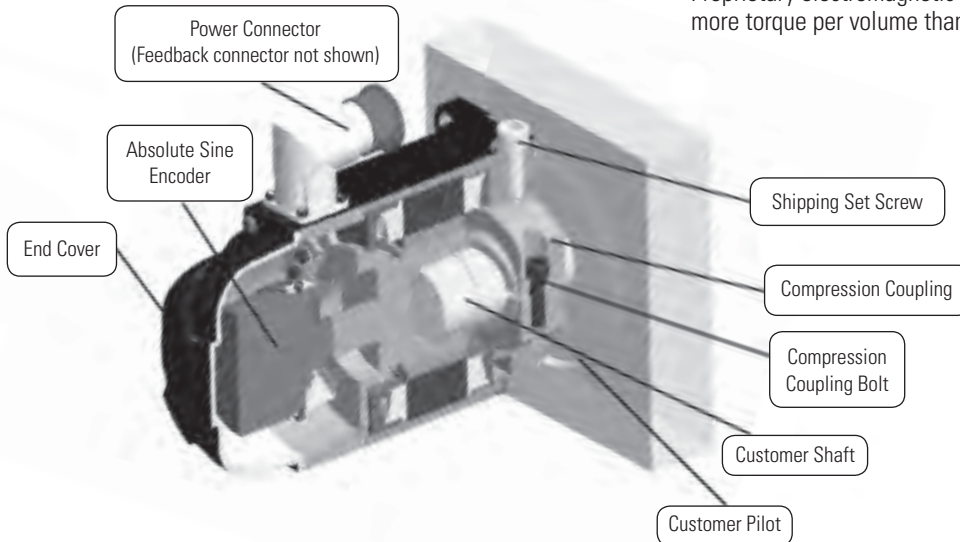

The Cartridge DDR Advantage – Press Feed Machine

Consider how Cartridge DDR technology improves a Press Feed machine:

Reduced Assembly Time

The assembly time for the original mechanical transmission system was 4 hours. In contrast, the Cartridge DDR motor is installed in less than 5 minutes, resulting in a significant cost savings in labor.

Reduced Parts Count

The original mechanical transmission system comprises 2 bracket pieces, 12 bolts, 2 pulleys, 2 set screws, 2 keys, a timing belt, a housing to protect operators from the timing belt, a tension system for the timing belt, and motor/gearhead. With the Cartridge DDR system, this is all replaced by the motor and 4 mounting bolts, resulting in fewer parts to maintain and cost savings.

Improved Accuracy

The best planetary gearheads have a backlash between 1 and 2 arc-minutes. Over the life of the gearhead, the backlash will increase. The Cartridge DDR system has an absolute accuracy of 26 arc-seconds and a repeatability of 0.7 arc-seconds. The Press Feed machine with the Cartridge DDR has a feed accuracy of +/- 0.0005 inch where the Press Feed machine with the mechanical transmission has a feed accuracy of 0.002 inch. Therefore, there was an overall four times improvement in machine accuracy with the Cartridge DDR system.

Increased Throughput

The cycle rate of the Cartridge DDR system is two times better than the mechanical transmission. This results in an increase in throughput of 100 percent.

Improved Reliability and Simplified Maintenance

The Cartridge DDR system eliminates parts that wear, change over time, or fail. Gearheads are prone to wear, and backlash increases over time. Belts and pulleys stretch and require maintenance to maintain proper belt tension. By eliminating these components, the Cartridge DDR system delivers greater system reliability.

Press Feed Example

Gearheads have a finite life span, especially in a demanding cyclic application such as a Press Feed. On this machine, the gearhead must be replaced every 10,000 hours and the belt must be tensioned every 2,000 hours. By contrast, the Cartridge DDR motor has no wear components and requires no maintenance thus simplifying the maintenance schedule for the machine, including operating costs.

Reduced Audible Noise

The Cartridge DDR system has as much as a 20 dB reduction in noise compared to a mechanical transmission servo system. This can dramatically reduce the overall noise level of the machine. A quieter machine gives the perception of quality. This is rightfully so as the noise emitted by gears and belts is caused by the wearing of the parts.

Total Reduced Cost

A Cartridge DDR motor typically costs 20 percent more than a comparable motor/gearhead combination. However, the elimination of parts and assembly time typically results in a lower total cost for the Cartridge DDR solution.



Press feed machine built with a conventional servomotor, gearhead, belt and pulleys.

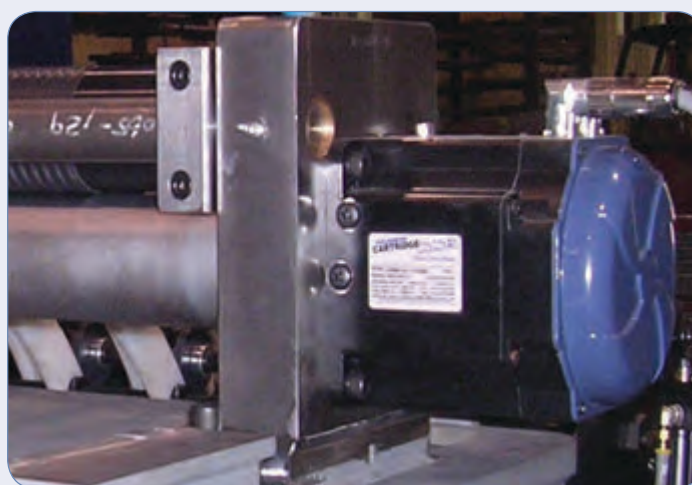

Same machine with a Cartridge DDR motor installed. Here, the shaft of the driven roll is extended into the Cartridge DDR motor and the motor applies torque directly to the driven roll.

Cartridge DDR System Summary

C A R T R I D G E D D R M O T O R

Due to the large range of continuous and peak torques for the Cartridge DDR series, the mechanical mounting and coupling to the machine varies.

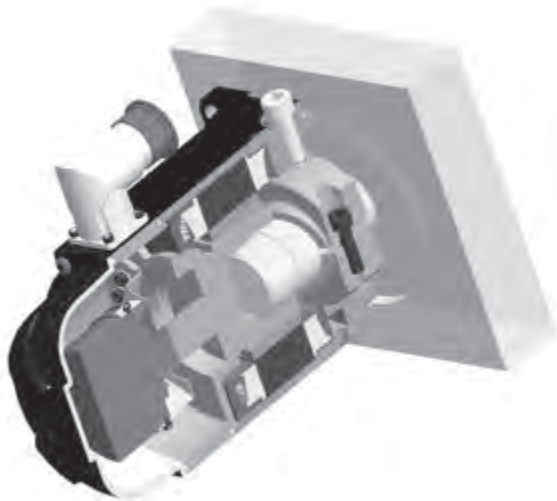

**Cross Section of
 C(H)04x, C(H)05x,
 C(H)06x**

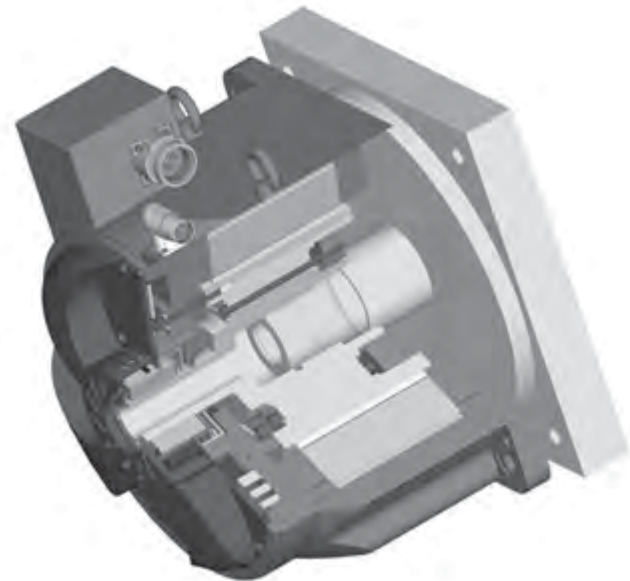

**Cross Section of
 C(H)09x, C(H)13x**

Machine Interface Summary

Parameter	C(H)04x, C(H)05x, C(H)06x	C(H)09x, C(H)13x
Coupling Technology	Single bolt split hub, access front motor	Multi-bolt compression, access from rear of motor
Mounting Requirements Shaft TIR	.005" (.13 mm)	.0015" (.038 mm)
Perpendicularity of Machine Mounting Face	.004" (.10 mm)	.002" (.051 mm)
Concentricity of Machine Pilot to Shaft	.004" (.10 mm)	.002" (.051 mm)
Shipping Hardware	Alignment bolt and cap screw	4 set screws and 4 shipping bolts
Mounting Procedure	Procedure # M-RT-S19-07	Procedure # M-RT-019-07

Performance Summary

		Performance Chart Page	AKD Servo Drive				S700 Drive	Performance				
			AKD-0030X	AKD-0060X	AKD-0120X	AKD-0240X	S748	Cont. Torque		Peak Torque		Maximum Speed
								(N-m)	lb-ft	(N-m)	lb-ft	
Cartridge DDR Motors	240 Volt Systems	C041A	18	•				4.57	3.37	12.3	9.09	1750
		C041B	20		•			4.52	3.33	12.2	9.01	2500
		C042A	18		•			8.25	6.08	22.2	16.4	1700
		C042B	20			•		8.45	6.23	22.8	16.8	2500
		C043A	18		•			11.1	8.20	30.0	22.1	1250
		C043B	20			•		11.2	8.23	30.2	22.2	2500
		C044A	18		•			13.9	10.3	37.4	27.6	1050
		C044B	20			•		14.1	10.4	37.9	28.0	2150
		C051A	21		•			11.7	8.66	30.2	22.3	1200
		C051B	23			•		11.9	8.77	30.6	22.6	2450
		C052C	21		•			16.9	12.5	43.1	31.8	950
		C052D	23			•		16.5	12.2	42.3	31.5	2050
		C053A	21			•		21.0	15.5	54.1	39.9	1350
		C053B	23				•	20.2	14.9	50.1	37.0	2500
		C054A	21			•		24.9	18.4	63.8	47.1	1200
		C054B	23				•	23.8	17.6	61.2	45.1	2350
		C061A	24			•		33.8	24.9	86.8	64.1	900
		C061B	26				•	32.6	24.1	75.6	55.7	1950
		C062C	24			•		48.4	35.7	117	86.5	700
		C062B	26				•	44.6	32.9	102	75.2	1400
		C063C	24			•		61.8	45.6	157	115	550
		C063B	26				•	59.0	43.5	136	100	1050
		C091A	27				•	50.2	37.0	120	88.2	600
		C092C	27				•	102	74.9	231	170	450
		C093C	27				•	139	103	317	233	350
		C131C	29				•	189	139	395	291	250
		C131B	31					•	190	140	396	292
	C132C	29				•	362	267	818	603	120	
	C132B	31					•	361	266	759	560	225
	C133C	29				•	499	368	1070	791	100	
	C133B	31					•	510	376	1016	749	175
	400 / 480 Volt Systems	CH041A	19	•				4.56	3.37	11.3	8.33	2500
		CH042A	19		•			8.26	6.09	19.0	14.0	2500
CH043A		19		•			11.1	8.20	25.3	18.7	2500 ¹	
CH044A		19		•			13.9	10.2	31.6	23.3	2250 ¹	
CH051A		22	•				11.7	8.66	28.0	20.7	2500 ¹	
CH052C		22	•				16.9	12.5	43.1	31.8	2100	
CH053A		22		•			21.0	15.5	54.1	39.9	2500 ¹	
CH054A		22		•			24.9	18.4	63.8	47.1	2500 ¹	
CH061A		25		•			33.8	24.9	86.8	64.1	1900 ¹	
CH062C		25		•			48.4	35.7	117	86.5	1550 ¹	
CH063C		25		•			61.8	45.6	157	115	1150 ¹	
CH063B		25			•		59.0	43.5	136	100	2200 ¹	
CH091A		28			•		50.2	37.0	120	88.2	1500 ¹	
CH092C		28			•		102	74.9	231	170	1000 ¹	
CH093C		28			•		139	103	317	233	800 ¹	
CH131C		30				•	189	139	395	291	600 ¹	
CH131B		32					•	190	140	396	292	1000 ¹
CH132C		30				•	362	267	818	603	300 ¹	
CH132B		32					•	361	266	759	560	500 ¹
CH133C		30				•	499	368	1070	791	250 ¹	
CH133B	32					•	510	376	1016	749	400 ¹	

1. Maximum speed at 480 Vac. For maximum speed at 400 Vac see performance curve.

Technical Performance Data

C04xA

System Performance at 240 VAC C04xA Cartridge DDR Motor with AKD Servo Drive Series Amplifier

System Performance	Symbol	Units	C041A	C042A	C043A	C044A
Continuous Torque 100°C Rise ¹²³	T _c	lb-ft (N-m)	3.37 (4.57)	6.08 (8.25)	8.20 (11.1)	10.3 (13.9)
Cont. Line Current	I _c	amps RMS	2.73	4.68	4.73	4.91
Continuous Torque 70°C Rise ¹²³	T _c	lb-ft (N-m)	2.93 (3.97)	5.30 (7.19)	7.14 (9.68)	9.14 (12.4)
Cont. Line Current	I _c	amps RMS	2.38	4.08	4.13	4.37
Peak Torque	T _p	lb-ft (N-m)	9.09 (12.3)	16.4 (22.2)	22.1 (30.0)	27.6 (37.4)
Peak Line Current	I _p	amps RMS	8.20	14.0	14.2	14.7
Maximum Speed	N max	RPM	1750	1700	1250	1050
Weight	Wt	lb (kg)	9.00 (4.08)	12.5 (5.67)	16.0 (7.26)	19.5 (8.84)
Rotor Inertia	Jm	oz-in-sec ² (kg-cm ²)	0.083 (5.86)	0.126 (8.87)	0.168 (11.9)	0.211 (14.9)

CARTRIDGE DDR MOTOR

TECHNICAL PERFORMANCE DATA

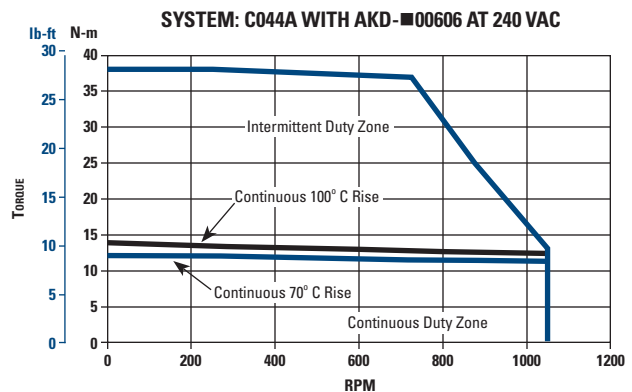
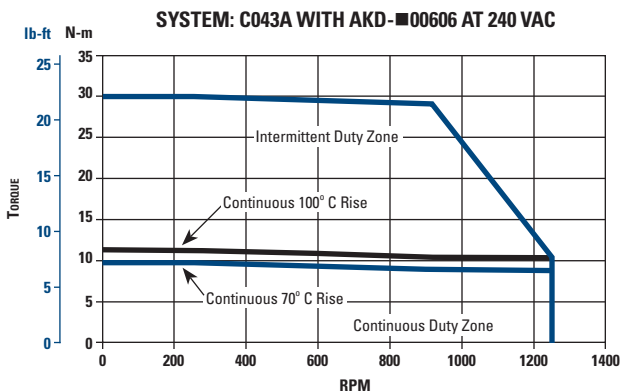
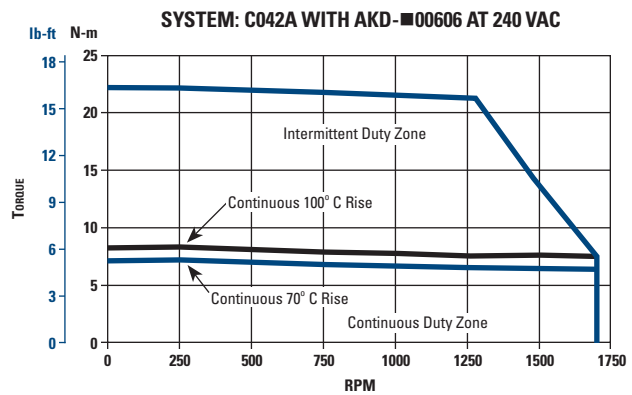
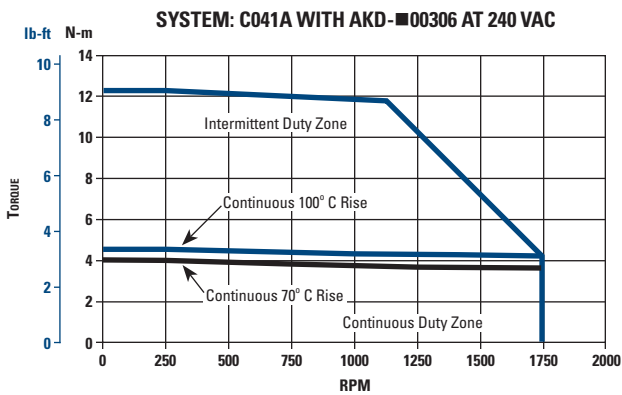

- Notes:
1. At 40°C ambient.
 2. Increase T_c by 1.06 times for 25°C ambient.
 3. Temperature rise assumes a 12 x 12 x 0.50 inch aluminum mounting plate or equivalent.

CH04xA

System Performance at 400/480 VAC CH04xA Cartridge DDR Motor with AKD Servo Drive Series Amplifier

System Performance	Symbol	Units	CH041A	CH042A	CH043A	CH044A
Continuous Torque 100°C Rise ¹²³	Tc	lb-ft (N-m)	3.37 (4.56)	6.09 (8.26)	8.20 (11.1)	10.2 (13.9)
Cont. Line Current	Ic	amps RMS	2.73	4.68	4.73	4.90
Continuous Torque 70°C Rise ¹²³	Tc	lb-ft (N-m)	2.93 (3.97)	5.30 (7.19)	7.14 (9.68)	9.14 (12.4)
Cont. Line Current	Ic	amps RMS	2.38	4.08	4.13	4.30
Peak Torque	Tp	lb-ft (N-m)	8.33 (11.3)	14.0 (19.0)	18.7 (25.3)	23.3 (31.6)
Peak Line Current	Ip	amps RMS	7.50	12.0	12.0	12.0
Maximum Speed (400 V) Maximum Speed (480 V)	N max	RPM	2500 2500	2500 2500	2250 2500	1850 2250
Weight	Wt	lb (kg)	9.00 (4.08)	12.5 (5.67)	16.0 (7.26)	19.5 (8.84)
Rotor Inertia	Jm	oz-in-sec ² (kg-cm ²)	0.083 (5.86)	0.126 (8.87)	0.168 (11.9)	0.211 (14.9)

CARTRIDGE DDR MOTOR TECHNICAL PERFORMANCE DATA

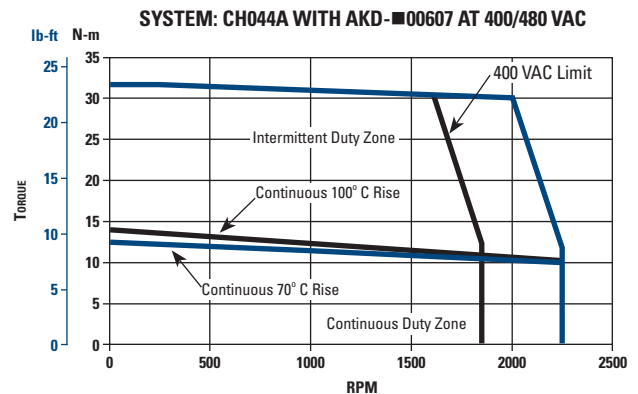
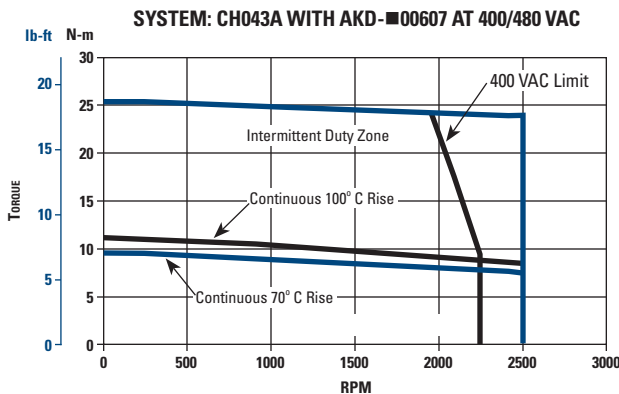
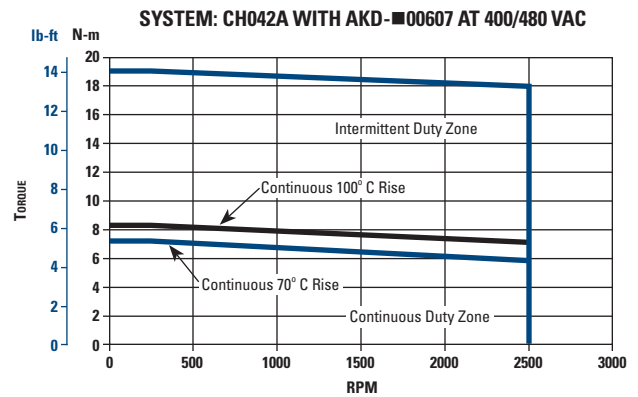
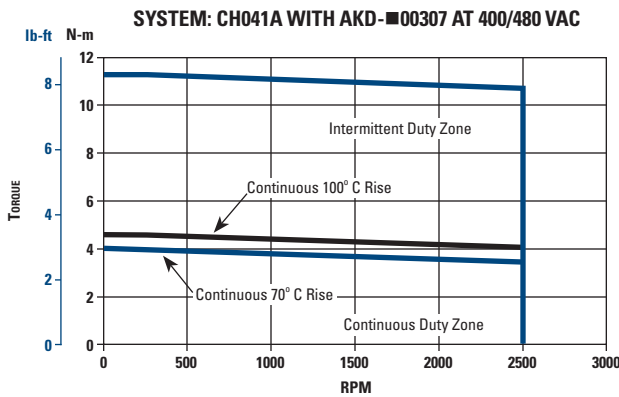

- Notes:
1. At 40°C ambient.
 2. Increase Tc by 1.06 times for 25°C ambient.
 3. Temperature rise assumes a 12 x 12 x 0.50 inch aluminum mounting plate or equivalent.

Technical Performance Data

C04xB

System Performance at 240 VAC C04xB Cartridge DDR Motor (High-Speed Winding) with AKD Servo Drive Series Amplifiers

System Performance	Symbol	Units	C041B	C042B	C043B	C044B
Continuous Torque 100°C Rise ¹²³	T _c	lb-ft (N-m)	3.33 (4.52)	6.23 (8.45)	8.23 (11.2)	10.4 (14.1)
Cont. Line Current	I _c	amps RMS	4.69	9.19	9.15	9.53
Continuous Torque 70°C Rise ¹²³	T _c	lb-ft (N-m)	2.91 (3.94)	5.43 (7.36)	7.17 (9.73)	9.22 (12.5)
Cont. Line Current	I _c	amps RMS	4.09	8.01	7.98	8.50
Peak Torque	T _p	lb-ft (N-m)	9.01 (12.2)	16.8 (22.8)	22.2 (30.2)	28.0 (37.9)
Peak Line Current	I _p	amps RMS	14.1	27.6	27.5	28.6
Maximum Speed	N max	RPM	2500	2500	2500	2150
Weight	W _t	lb (kg)	9.00 (4.08)	12.5 (5.67)	16.0 (7.26)	19.5 (8.84)
Rotor Inertia	J _m	oz-in-sec ² (kg-cm ²)	0.083 (5.86)	0.126 (8.87)	0.168 (11.9)	0.211 (14.9)

SYSTEM: C041B WITH AKD-00606 AT 240 VAC

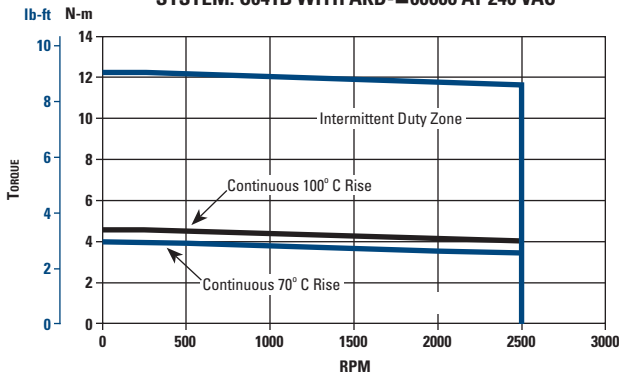

SYSTEM: C042B WITH AKD-01206 AT 240 VAC

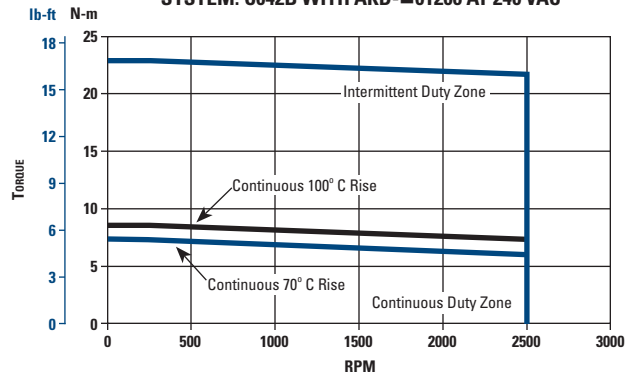

SYSTEM: C043B WITH AKD-01206 AT 240 VAC

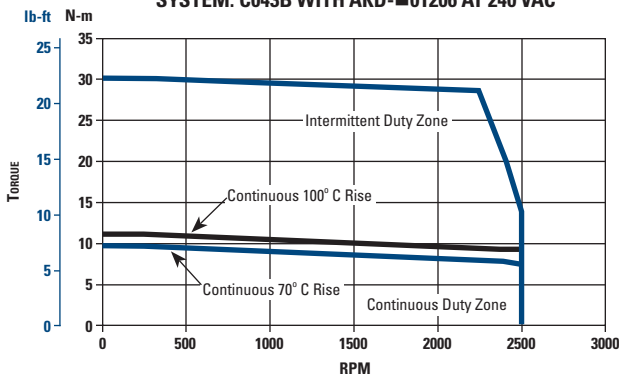

SYSTEM: C044B WITH AKD-01206 AT 240 VAC

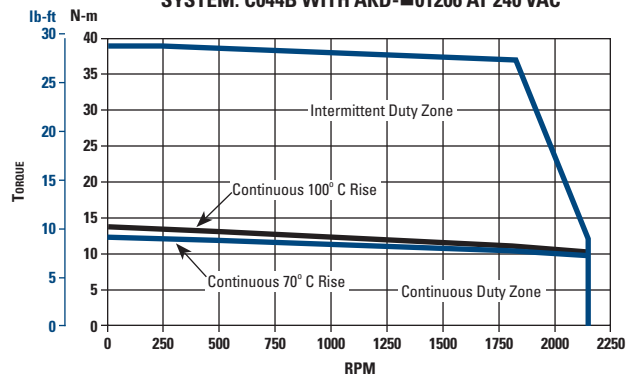

Notes:

1. At 40°C ambient.
2. Increase T_c by 1.06 times for 25°C ambient.
3. Temperature rise assumes a 12 x 12 x 0.50 inch aluminum mounting plate or equivalent.

C05xA/C

System Performance at 240 VAC C05xA/C Cartridge DDR Motor with AKD Servo Drive Series Amplifiers

System Performance	Symbol	Units	C051A	C052C	C053A	C054A
Continuous Torque 100°C Rise ¹²³	T _c	lb-ft (N-m)	8.66 (11.7)	12.5 (16.9)	15.5 (21.0)	18.4 (24.9)
Cont. Line Current	I _c	amps RMS	4.78	5.73	9.28	9.82
Continuous Torque 70°C Rise ¹²³	T _c	lb-ft (N-m)	7.54 (10.2)	10.8 (14.7)	13.5 (18.3)	16.1 (21.8)
Cont. Line Current	I _c	amps RMS	4.17	5.00	8.10	8.62
Peak Torque	T _p	lb-ft (N-m)	22.3 (30.2)	31.8 (43.1)	39.9 (54.1)	47.1 (63.8)
Peak Line Current	I _p	amps RMS	12.9	15.5	25.1	26.5
Maximum Speed	N max	RPM	1200	950	1350	1200
Weight	Wt	lb (kg)	18.5 (8.39)	23.5 (10.7)	29.0 (13.2)	34.0 (15.4)
Rotor Inertia	J _m	oz-in-sec ² (kg-cm ²)	0.388 (27.4)	0.508 (35.9)	0.628 (44.3)	0.748 (52.8)

CARTRIDGE DDR MOTOR TECHNICAL PERFORMANCE DATA

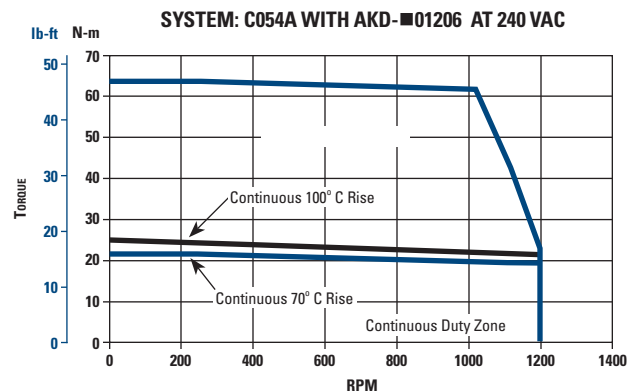
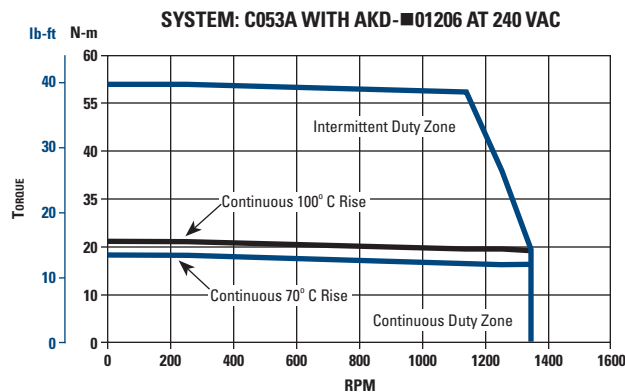
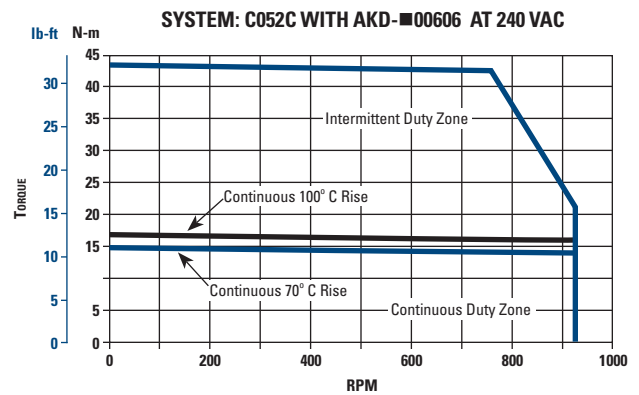
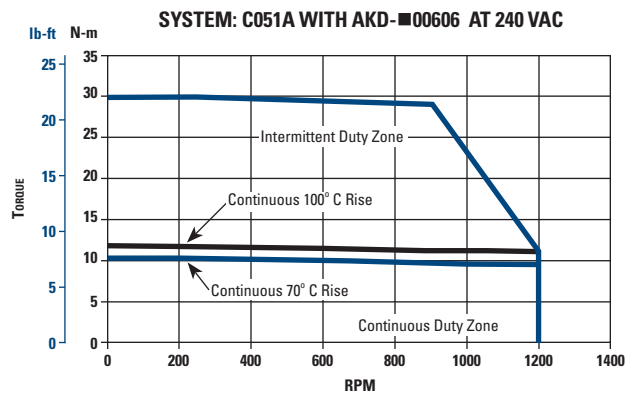

- Notes:
1. At 40°C ambient.
 2. Increase T_c by 1.06 times for 25°C ambient.
 3. Temperature rise assumes a 18 x 18 x 0.50 inch aluminum mounting plate or equivalent.

Technical Performance Data

CH05xA

System Performance at 400/480 VAC CH05xA/C Cartridge DDR Motor with AKD Servo Drive Series Amplifiers

System Performance	Symbol	Units	CH051A	CH052C	CH053A	CH054A
Continuous Torque 100°C Rise ¹²³	T _c	lb-ft (N-m)	8.66 (11.7)	12.5 (16.9)	15.5 (21.0)	18.4 (24.9)
Cont. Line Current	I _c	amps RMS	4.78	5.73	9.28	9.82
Continuous Torque 70°C Rise ¹²³	T _c	lb-ft (N-m)	7.54 (10.2)	10.8 (14.7)	13.5 (18.3)	16.1 (21.8)
Cont. Line Current	I _c	amps RMS	4.17	5.00	8.10	8.62
Peak Torque	T _p	lb-ft (N-m)	20.7 (28.0)	31.8 (43.1)	39.9 (54.1)	47.1 (63.8)
Peak Line Current	I _p	amps RMS	12.0	15.5	25.1	26.5
Maximum Speed (400 V) Maximum Speed (480 V)	N max	RPM	2100 2500	1750 2100	2350 2500	2100 2500
Weight	W _t	lb (kg)	18.5 (8.39)	23.5 (10.7)	29.0 (13.2)	34.0 (15.4)
Rotor Inertia	J _m	oz-in-sec ² (kg-cm ²)	0.388 (27.4)	0.508 (35.9)	0.628 (44.3)	0.748 (52.8)

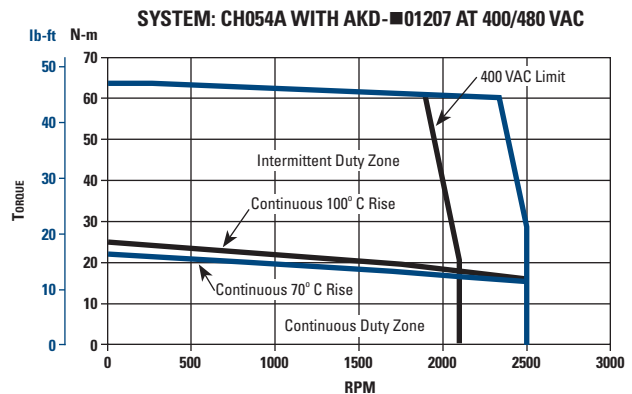
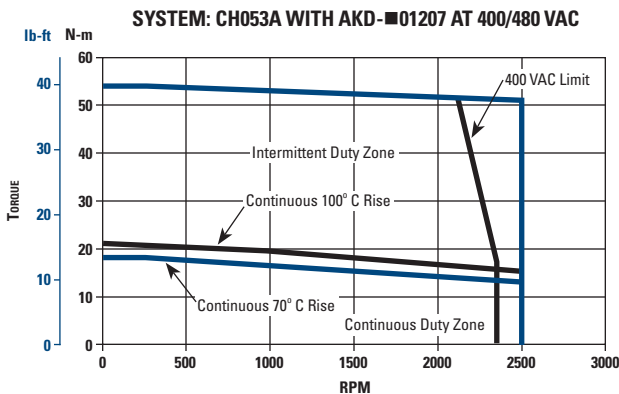
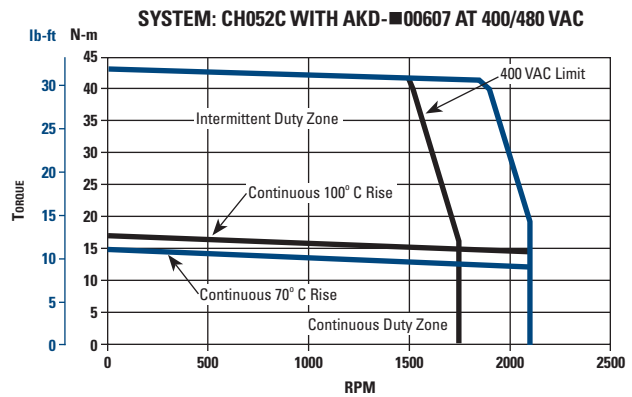
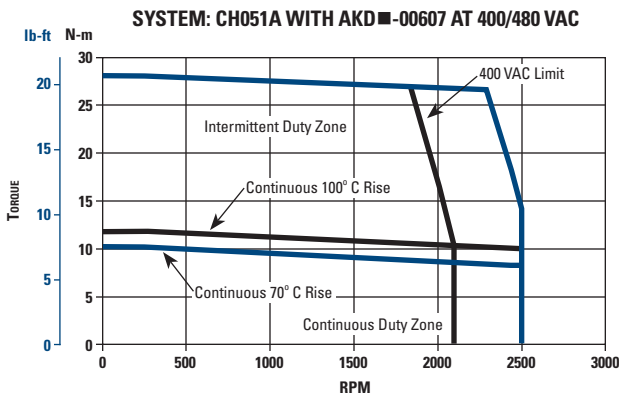

- Notes:
1. At 40°C ambient.
 2. Increase T_c by 1.06 times for 25°C ambient.
 3. Temperature rise assumes a 18 x 18 x 0.50 inch aluminum mounting plate or equivalent.

C05xB/D

System Performance at 240 VAC C05xB/D Cartridge DDR Motor (High-Speed Winding) with AKD Servo Drive Series Amplifiers

System Performance	Symbol	Units	C051B	C052D	C053B	C054B
Continuous Torque 100°C Rise ¹²³	Tc	lb-ft (N-m)	8.77 (11.9)	12.2 (16.5)	14.9 (20.2)	17.6 (23.8)
Cont. Line Current	Ic	amps RMS	9.34	10.9	18.4	17.4
Continuous Torque 70°C Rise ¹²³	Tc	lb-ft (N-m)	7.63 (10.4)	10.6 (14.4)	12.9 (17.6)	15.4 (20.9)
Cont. Line Current	Ic	amps RMS	8.15	9.55	16.0	15.3
Peak Torque	Tp	lb-ft (N-m)	22.6 (30.6)	31.2 (42.3)	37.0 (50.1)	45.1 (61.2)
Peak Line Current	Ip	amps RMS	25.2	29.6	48.0	47.0
Maximum Speed	N max	RPM	2450	2050	2500	2350
Weight	Wt	lb (kg)	18.5 (8.39)	23.5 (10.7)	29.0 (13.2)	34.0 (15.4)
Rotor Inertia	Jm	oz-in-sec ² (kg-cm ²)	0.388 (27.4)	0.508 (35.9)	0.628 (44.3)	0.748 (52.8)

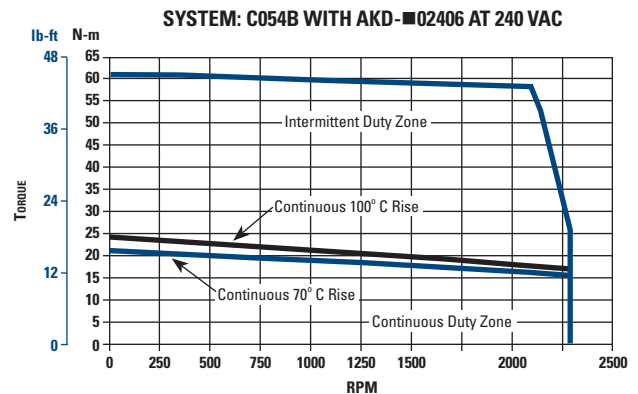
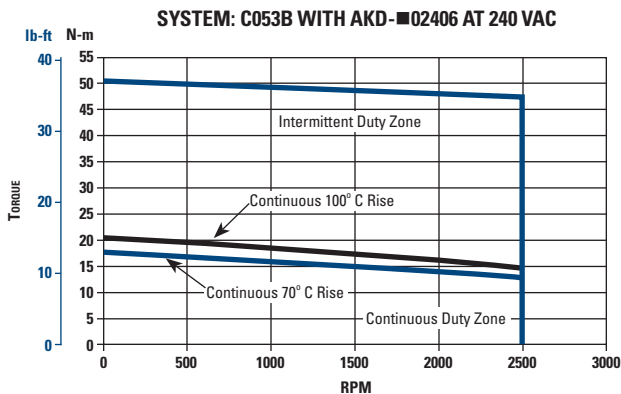
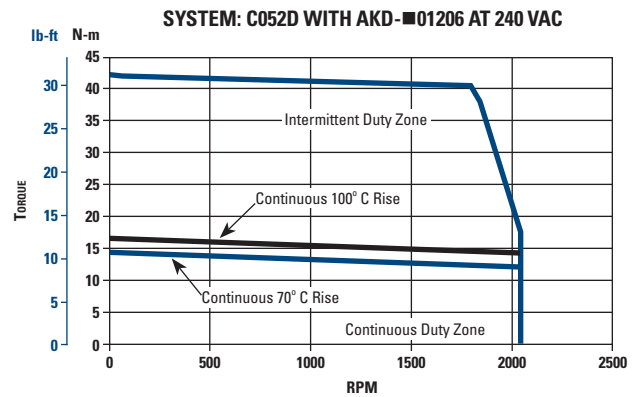
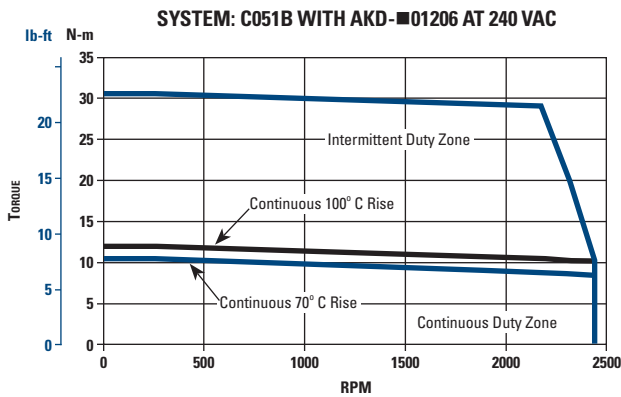

- Notes:
1. At 40°C ambient.
 2. Increase Tc by 1.06 times for 25°C ambient.
 3. Temperature rise assumes a 18 x 18 x 0.50 inch aluminum mounting plate or equivalent.

Technical Performance Data

C06xA/C

System Performance at 240 VAC C06xA/C Cartridge DDR Motor with AKD Servo Drive Series Amplifiers

System Performance	Symbol	Units	C061A	C062C	C063C
Continuous Torque 100°C Rise ¹²³	T _c	lb-ft (N-m)	24.9 (33.8)	35.7 (48.4)	45.6 (61.8)
Cont. Line Current	I _c	amps RMS	10.0	11.8	11.3
Continuous Torque 70°C Rise ¹²³	T _c	lb-ft (N-m)	21.7 (29.4)	31.1 (42.2)	39.7 (53.9)
Cont. Line Current	I _c	amps RMS	8.72	10.3	9.84
Peak Torque	T _p	lb-ft (N-m)	64.1 (86.8)	86.5 (117)	115 (157)
Peak Line Current	I _p	amps RMS	27.0	30.0	30.0
Maximum Speed	N max	RPM	900	700	550
Weight	Wt	lb (kg)	41.0 (18.6)	52.0 (23.6)	63.0 (29.0)
Rotor Inertia	J _m	oz-in-sec ² (kg-cm ²)	1.33 (94.1)	1.78 (126)	2.23 (157)

SYSTEM: C061A WITH AKD-01206 AT 240 VAC

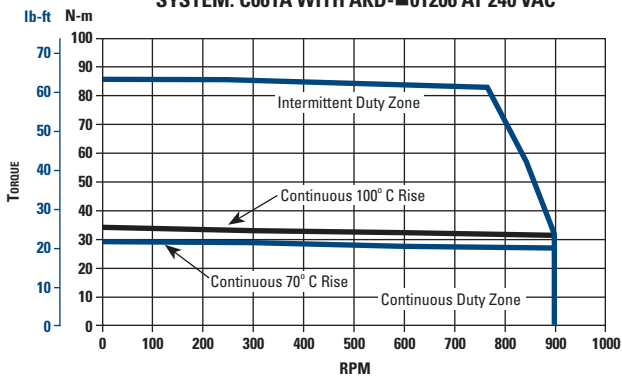

SYSTEM: C062C WITH AKD-01206 AT 240 VAC

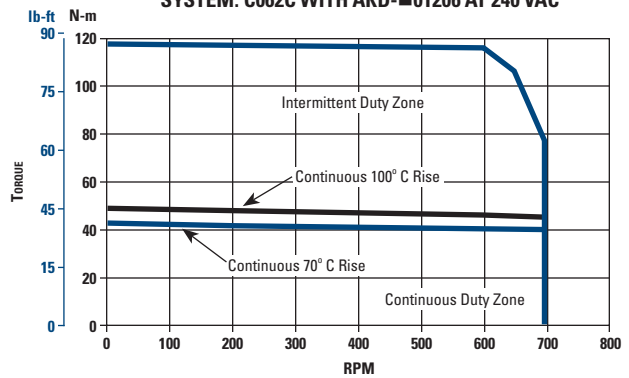

SYSTEM: C063C WITH AKD-01206 AT 240 VAC

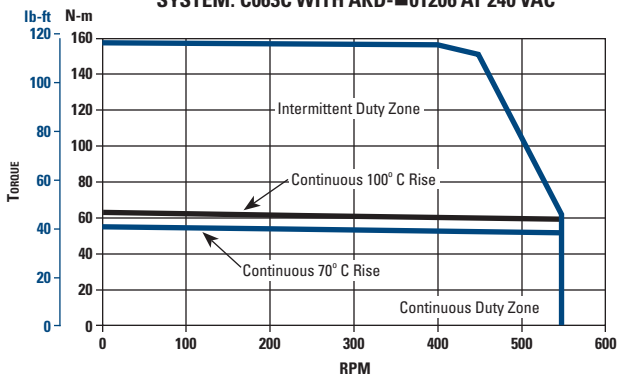

Notes:

1. At 40°C ambient.
2. Increase T_c by 1.06 times for 25°C ambient.
3. Temperature rise assumes a 18 x 18 x 0.50 inch aluminum mounting plate or equivalent.

CARTRIDGE DDR MOTOR
 TECHNICAL PERFORMANCE DATA

CH06x

System Performance at 400 / 480 VAC CH06x Cartridge DDR Motor with AKD Servo Drive Series Amplifier

System Performance	Symbol	Units	CH061A	CH062C	CH063C	CH063B
Continuous Torque 100°C Rise ¹²³	Tc	lb-ft (N-m)	24.9 (33.8)	35.7 (48.4)	45.6 (61.8)	43.5 (59.0)
Cont. Line Current	Ic	amps RMS	10.0	11.8	11.3	19.8
Continuous Torque 70°C Rise ¹²³	Tc	lb-ft (N-m)	21.7 (29.4)	31.1 (42.2)	39.7 (53.9)	37.9 (51.4)
Cont. Line Current	Ic	amps RMS	8.72	10.3	9.84	17.3
Peak Torque	Tp	lb-ft (N-m)	64.1 (86.8)	86.5 (117)	115 (157)	100 (136)
Peak Line Current	Ip	amps RMS	27.0	30.0	30.0	48.0
Maximum Speed (400 V) Maximum Speed (480 V)	N max	RPM	1600 1900	1250 1550	950 1150	1850 2200
Weight	Wt	lb (kg)	41.0 (18.6)	52.0 (23.6)	63.0 (29.0)	63.0 (29.0)
Rotor Inertia	Jm	oz-in-sec ² (kg-cm ²)	1.33 (94.1)	1.78 (126)	2.23 (157)	2.23 (157)

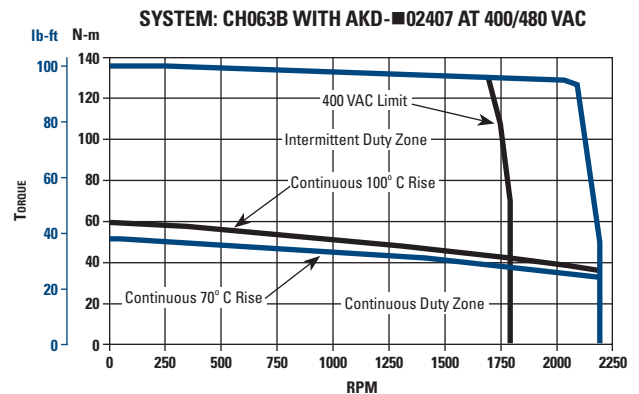
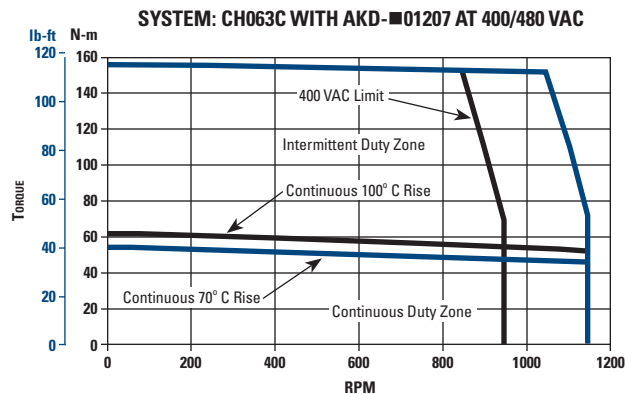
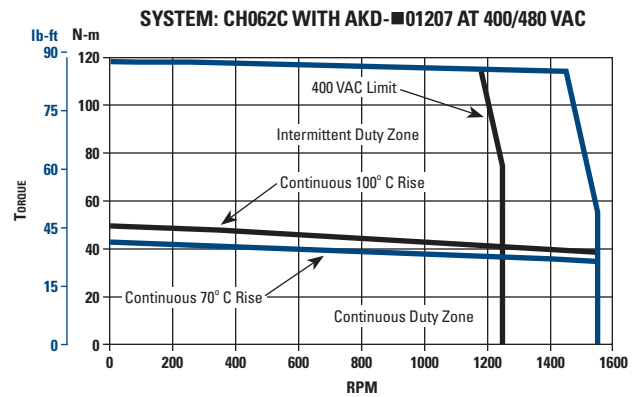
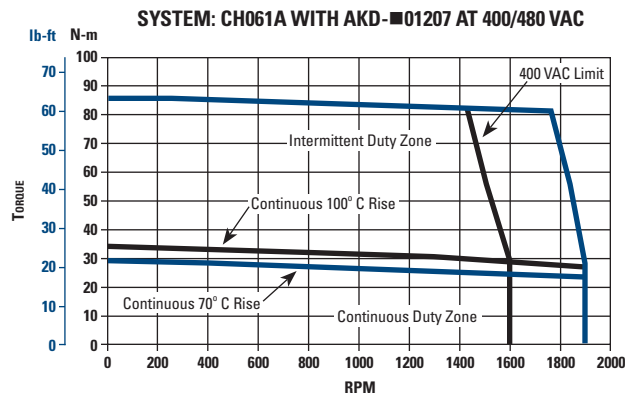

- Notes:
1. At 40°C ambient.
 2. Increase Tc by 1.06 times for 25°C ambient.
 3. Temperature rise assumes a 18 x 18 x 0.50 inch aluminum mounting plate or equivalent.

Technical Performance Data

C06xB

System Performance at 240 VAC C06xB Cartridge DDR Motor (High-Speed Winding) with AKD Servo Drive Series Amplifier

System Performance	Symbol	Units	C061B	C062B	C063B
Continuous Torque 100°C Rise ¹²³	T _c	lb-ft (N-m)	24.1 (32.6)	32.9 (44.6)	43.5 (59.0)
Cont. Line Current	I _c	amps RMS	19.7	20.0	19.8
Continuous Torque 70°C Rise ¹²³	T _c	lb-ft (N-m)	21.0 (28.4)	29.9 (40.5)	37.9 (51.4)
Cont. Line Current	I _c	amps RMS	17.2	18.2	17.3
Peak Torque	T _p	lb-ft (N-m)	55.7 (75.6)	75.2 (102)	100 (136)
Peak Line Current	I _p	amps RMS	48.0	48.0	48.0
Maximum Speed	N max	RPM	1950	1400	1050
Weight	Wt	lb (kg)	41.0 (18.6)	52.0 (23.6)	63.0 (29.0)
Rotor Inertia	J _m	oz-in-sec ² (kg-cm ²)	1.33 (94.1)	1.78 (126)	2.23 (157)

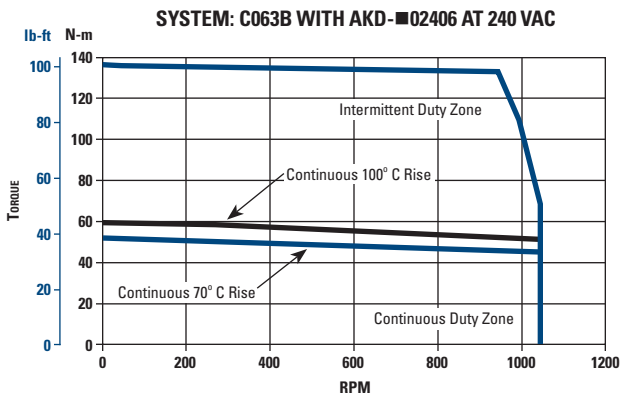
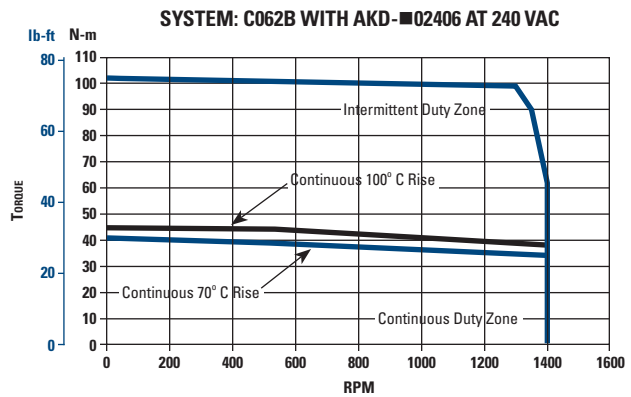
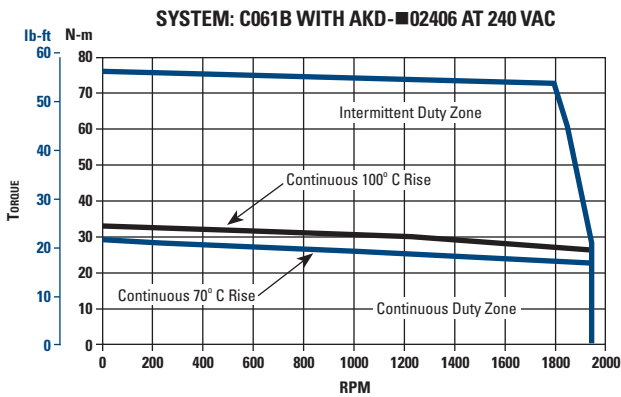

- Notes:
1. At 40°C ambient.
 2. Increase T_c by 1.06 times for 25°C ambient.
 3. Temperature rise assumes a 18 x 18 x 0.50 inch aluminum mounting plate or equivalent.

C09xA/C

System Performance at 230 VAC C09xA/C Cartridge DDR Motor with AKD Drive Amplifiers

System Performance	Symbol	Units	C091A	C092C	C093C
Continuous Torque 110°C Rise	Tc	lb-ft (N-m)	37.0 (50.2)	74.9 (102)	103 (139)
Cont. Line Current	Ic	amps RMS	12.8	18.1	20.0
Continuous Torque 80°C Rise	Tc	lb-ft (N-m)	33.0 (44.7)	66.5 (90.1)	95.0 (129)
Cont. Line Current	Ic	amps RMS	11.4	13.7	15.6
Peak Torque	Tp	lb-ft (N-m)	88.2 (120)	170 (231)	234 (317)
Peak Line Current	Ip	amps RMS	40.0	48.0	48.0
Maximum Speed	N max	RPM	600	450	350
Weight	Wt	lb (kg)	61.0 (27.7)	91.0 (41.3)	120 (54.4)
Rotor Inertia	Jm	lb-ft-sec ² (kg-m ²)	0.021 (0.028)	0.035 (0.047)	0.049 (0.066)

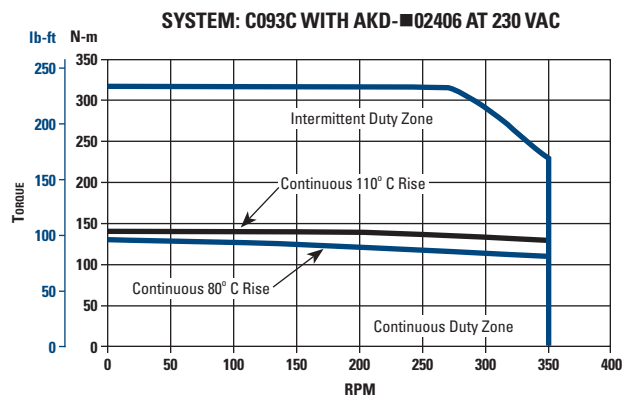
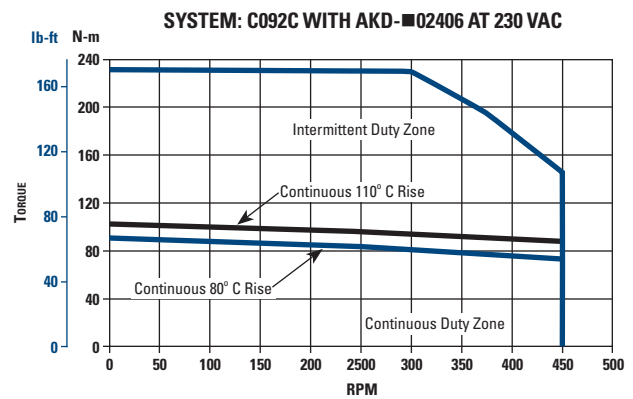
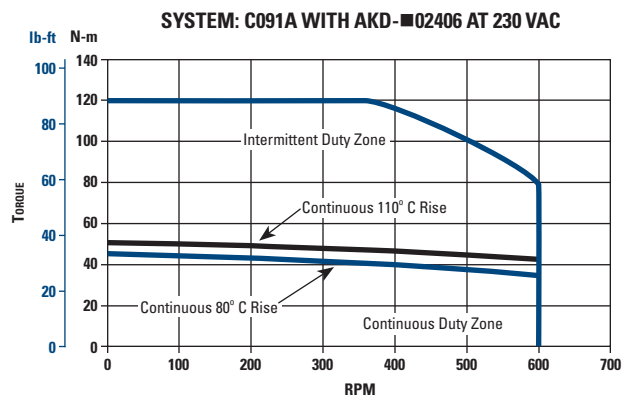

- Notes:
1. At 40°C ambient.
 2. Increase Tc by 1.06 times for 25°C ambient.
 3. Temperature rise assumes a 16 x 16 x 0.75 inch aluminum mounting plate or equivalent.

Technical Performance Data

CH09xA/C

System Performance at 400 /480 VAC CH09xA/C Cartridge DDR Motor with AKD Drive Amplifier

System Performance	Symbol	Units	CH091A	CH092C	CH093C
Continuous Torque 110°C Rise	T _c	lb-ft (N-m)	37.0 (50.2)	74.9 (102)	103 (139)
Cont. Line Current	I _c	amps RMS	12.8	18.1	20.0
Continuous Torque 80°C Rise	T _c	lb-ft (N-m)	33.0 (44.7)	66.5 (90.1)	95.0 (129)
Cont. Line Current	I _c	amps RMS	11.4	13.7	15.6
Peak Torque	T _p	lb-ft (N-m)	88.2 (120)	170 (231)	228 (309)
Peak Line Current	I _p	amps RMS	40.0	48.0	48.0
Maximum Speed (400V) Maximum Speed (480V)	N max	RPM	1200 1500	800 1000	700 800
Weight	Wt	lb (kg)	61.0 (27.7)	91.0 (41.3)	120 (54.4)
Rotor Inertia	Jm	lb-ft-sec ² (kg-m ²)	0.021 (0.028)	0.035 (0.047)	0.049 (0.066)

SYSTEM: CH091A WITH AKD-■02407 AT 400/480 VAC

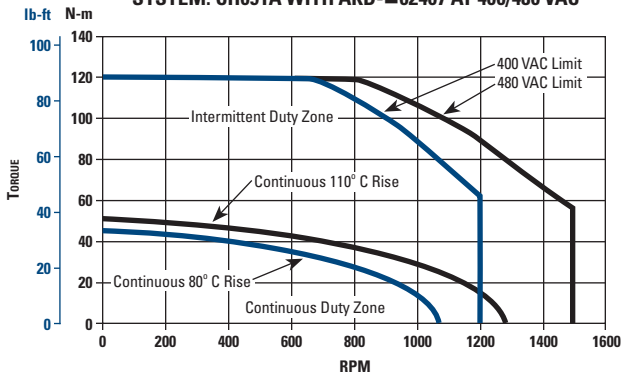

SYSTEM: CH092C WITH AKD-■02407 AT 400/480 VAC

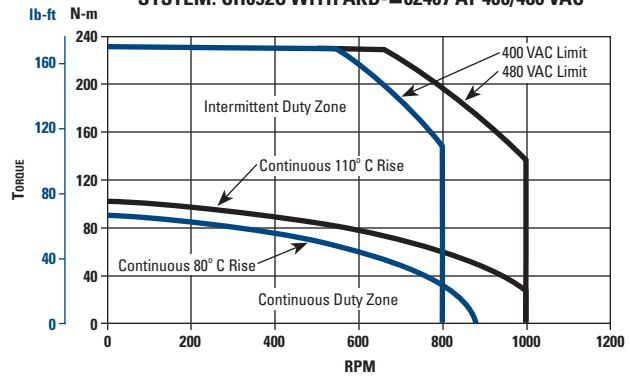

SYSTEM: CH093C WITH AKD-■02407 AT 400/480 VAC

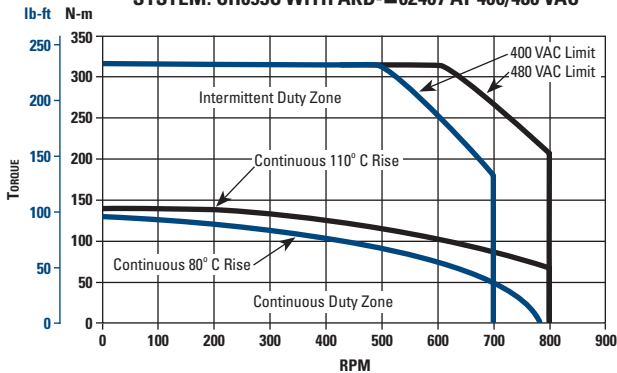

Notes:

1. At 40°C ambient.
2. Increase T_c by 1.06 times for 25°C ambient.
3. Temperature rise assumes a 16 x 16 x 0.75 inch aluminum mounting plate or equivalent.

C13xC

CARRIAGE DDR MOTOR TECHNICAL PERFORMANCE DATA

System Performance at 230 VAC C13xC Cartridge DDR Motor with AKD Drive Amplifier

System Performance	Symbol	Units	C131C	C132C	C133C
Continuous Torque 110°C Rise	Tc	lb-ft (N-m)	139 (189)	267 (362)	368 (499)
Cont. Line Current	Ic	amps RMS	18.8	16.9	20.0
Continuous Torque 80°C Rise	Tc	lb-ft (N-m)	123 (167)	236 (321)	330 (448)
Cont. Line Current	Ic	amps RMS	16.6	15.0	17.9
Peak Torque	Tp	lb-ft (N-m)	291 (395)	603 (818)	791 (1070)
Peak Line Current	Ip	amps RMS	48.0	48.0	48.0
Maximum Speed	N max	RPM	250	120	100
Weight	Wt	lb (kg)	140 (63.5)	223 (101)	292 (132)
Rotor Inertia	Jm	lb-ft-sec ² (kg-m ²)	0.091 (0.124)	0.166 (0.225)	0.223 (0.302)

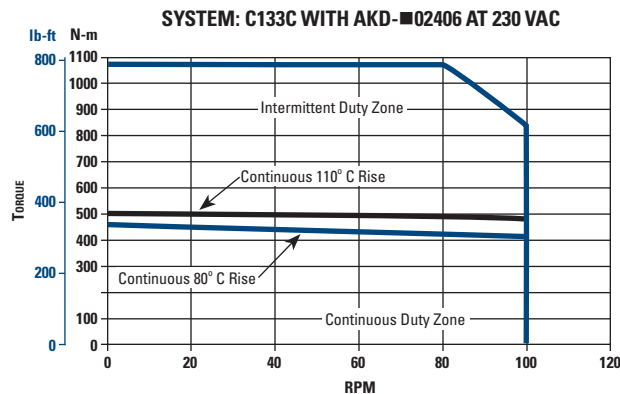
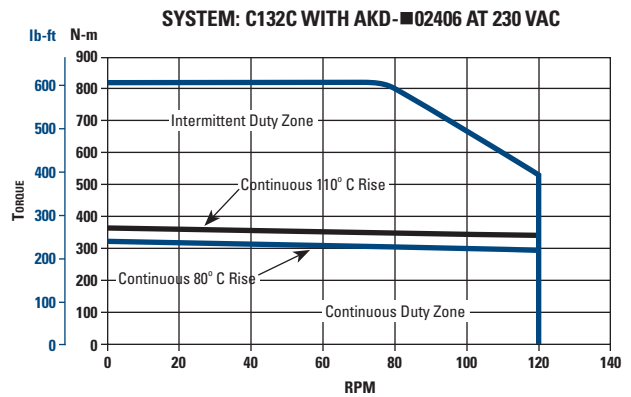
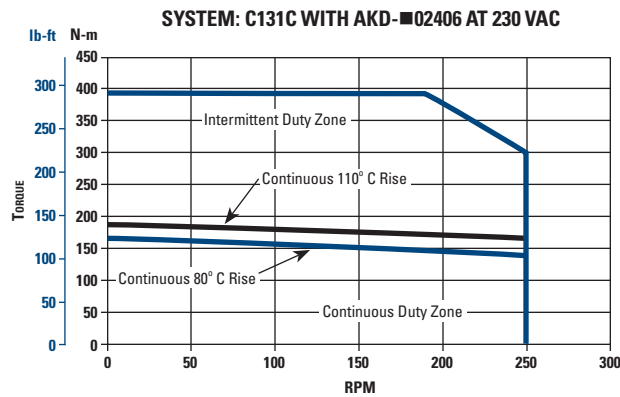

- Notes:
1. At 40°C ambient.
 2. Increase Tc by 1.06 times for 25°C ambient.
 3. Temperature rise assumes a 20 x 20 x 0.75 inch aluminum mounting plate or equivalent.

Technical Performance Data

CH13xC

System Performance at 400 /480 VAC CH13xC Cartridge DDR Motor with AKD Drive Amplifier

System Performance	Symbol	Units	CH131C	CH132C	CH133C
Continuous Torque 110°C Rise	Tc	lb-ft (N-m)	139 (189)	267 (362)	368 (499)
Cont. Line Current	Ic	amps RMS	18.8	16.9	20.0
Continuous Torque 80°C Rise	Tc	lb-ft (N-m)	123 (167)	236 (321)	330 (448)
Cont. Line Current	Ic	amps RMS	16.6	15.0	17.9
Peak Torque	Tp	lb-ft (N-m)	291 (395)	603 (818)	791 (1070)
Peak Line Current	Ip	amps RMS	48.0	48.0	48.0
Maximum Speed (400V) Maximum Speed (480V)	N max	RPM	500 600	250 300	200 250
Weight	Wt	lb (kg)	140 (63.5)	223 (101)	292 (132)
Rotor Inertia	Jm	lb-ft-sec ² (kg-m ²)	0.091 (0.124)	0.166 (0.225)	0.223 (0.302)

SYSTEM: CH131C WITH AKD-02407 AT 400/480 VAC

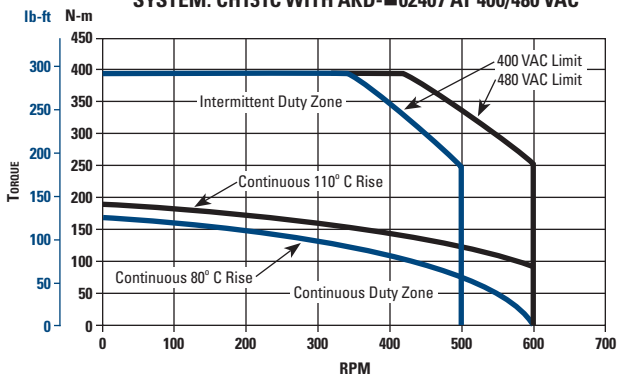

SYSTEM: CH132C WITH AKD-02407 AT 400/480 VAC

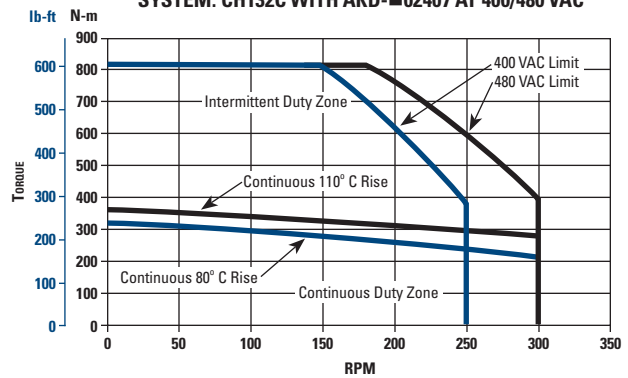

SYSTEM: CH133C WITH AKD-02407 AT 400/480 VAC

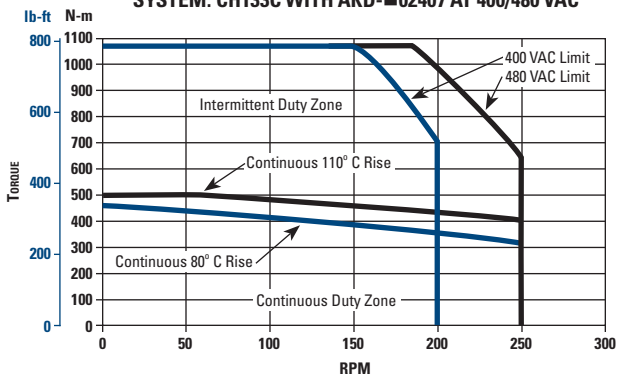

Notes:

1. At 40°C ambient.
2. Increase Tc by 1.06 times for 25°C ambient.
3. Temperature rise assumes a 20 x 20 x 0.75 inch aluminum mounting plate or equivalent.

C13xB

System Performance at 230 VAC C13xB Cartridge DDR Motor (High-Speed Winding) with S700 Drive Amplifier

System Performance	Symbol	Units	C131B	C132B	C133B
Continuous Torque 110°C Rise	Tc	lb-ft (N-m)	140 (190)	266 (361)	376 (510)
Cont. Line Current	lc	amps RMS	29.2	29.6	32.7
Continuous Torque 80°C Rise	Tc	lb-ft (N-m)	124 (168)	236 (320)	333 (451)
Cont. Line Current	lc	amps RMS	25.9	26.3	29.0
Peak Torque	Tp	lb-ft (N-m)	292 (396)	560 (759)	749 (1016)
Peak Line Current	lp	amps RMS	80.0	80.0	96.0
Maximum Speed	N max	RPM	450	225	175
Weight	Wt	lb (kg)	140 (63.5)	223 (101)	292 (132)
Rotor Inertia	Jm	lb-ft-sec ² (kg-m ²)	0.091 (0.124)	0.166 (0.225)	0.223 (0.302)

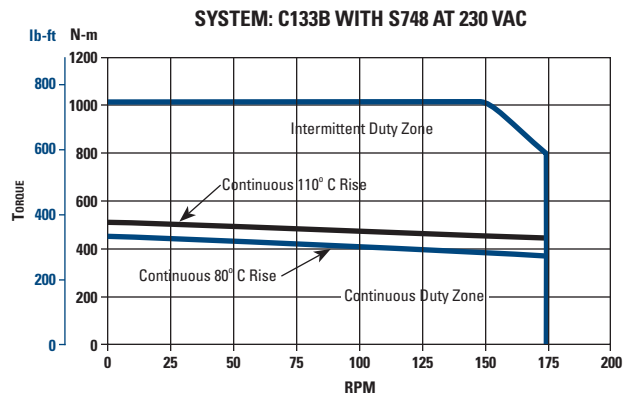
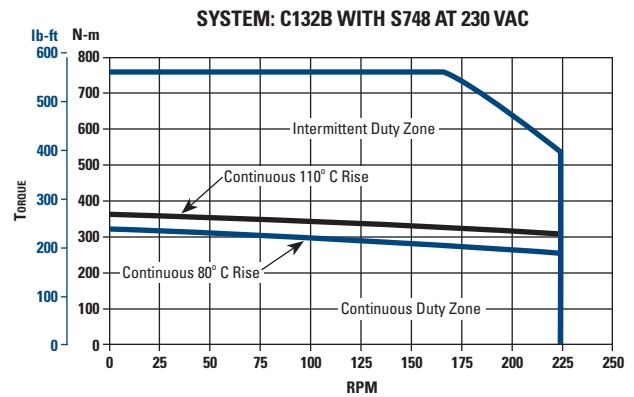
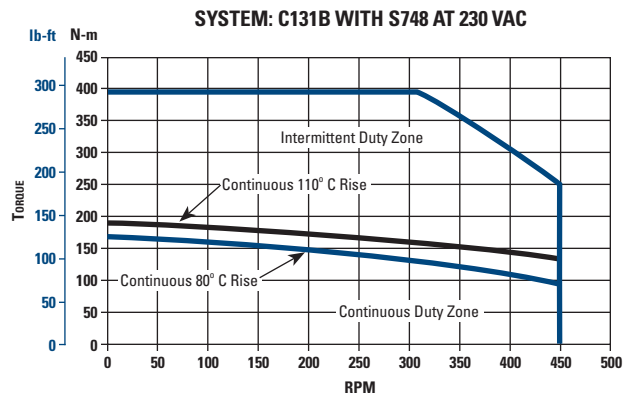

- Notes:
1. At 40°C ambient.
 2. Increase Tc by 1.06 times for 25°C ambient.
 3. Temperature rise assumes a 20 x 20 x 0.75 inch aluminum mounting plate or equivalent.

Technical Performance Data

CH13xB

System Performance at 400 /480 VAC CH13xB Cartridge DDR Motor (High-Speed Winding) with S700 Drive Amplifier

System Performance	Symbol	Units	CH131B	CH132B	CH133B
Continuous Torque 110°C Rise	Tc	lb-ft (N-m)	140 (190)	266 (361)	372 (510)
Cont. Line Current	Ic	amps RMS	29.2	29.6	32.7
Continuous Torque 80°C Rise	Tc	lb-ft (N-m)	124 (168)	236 (320)	333 (451)
Cont. Line Current	Ic	amps RMS	25.9	26.3	29.0
Peak Torque	Tp	lb-ft (N-m)	292 (396)	560 (759)	749 (1016)
Peak Line Current	Ip	amps RMS	80.0	80.0	96.0
Maximum Speed (400V) Maximum Speed (480V)	N max	RPM	800 1000	400 500	350 400
Weight	Wt	lb (kg)	140 (63.5)	223 (101)	292 (132)
Rotor Inertia	Jm	lb-ft-sec ² (kg-m ²)	0.091 (0.124)	0.166 (0.225)	0.223 (0.302)

SYSTEM: CH131B WITH S748 AT 400/480 VAC

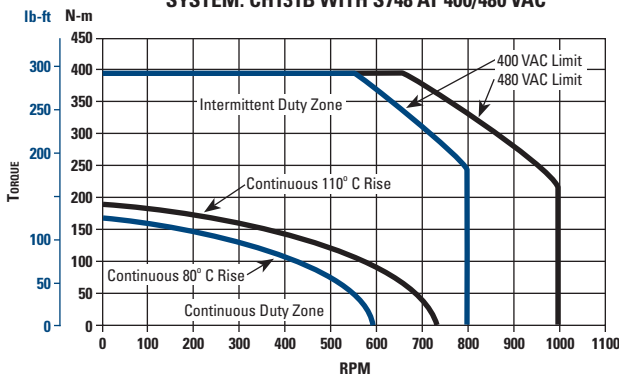

SYSTEM: CH132B WITH S748 AT 400/480 VAC

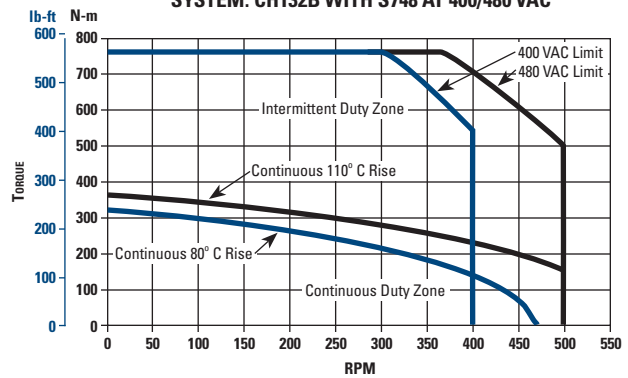

SYSTEM: CH133B WITH S748 AT 400/480 VAC

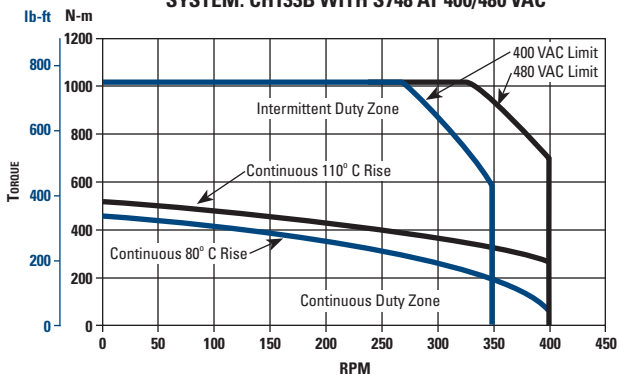

Notes:

1. At 40°C ambient.
2. Increase Tc by 1.06 times for 25°C ambient.
3. Temperature rise assumes a 20 x 20 x 0.75 inch aluminum mounting plate or equivalent.

Outline Drawings

C(H)04x

CARTRIDGE DDR MOTOR
 OUTLINE DRAWINGS

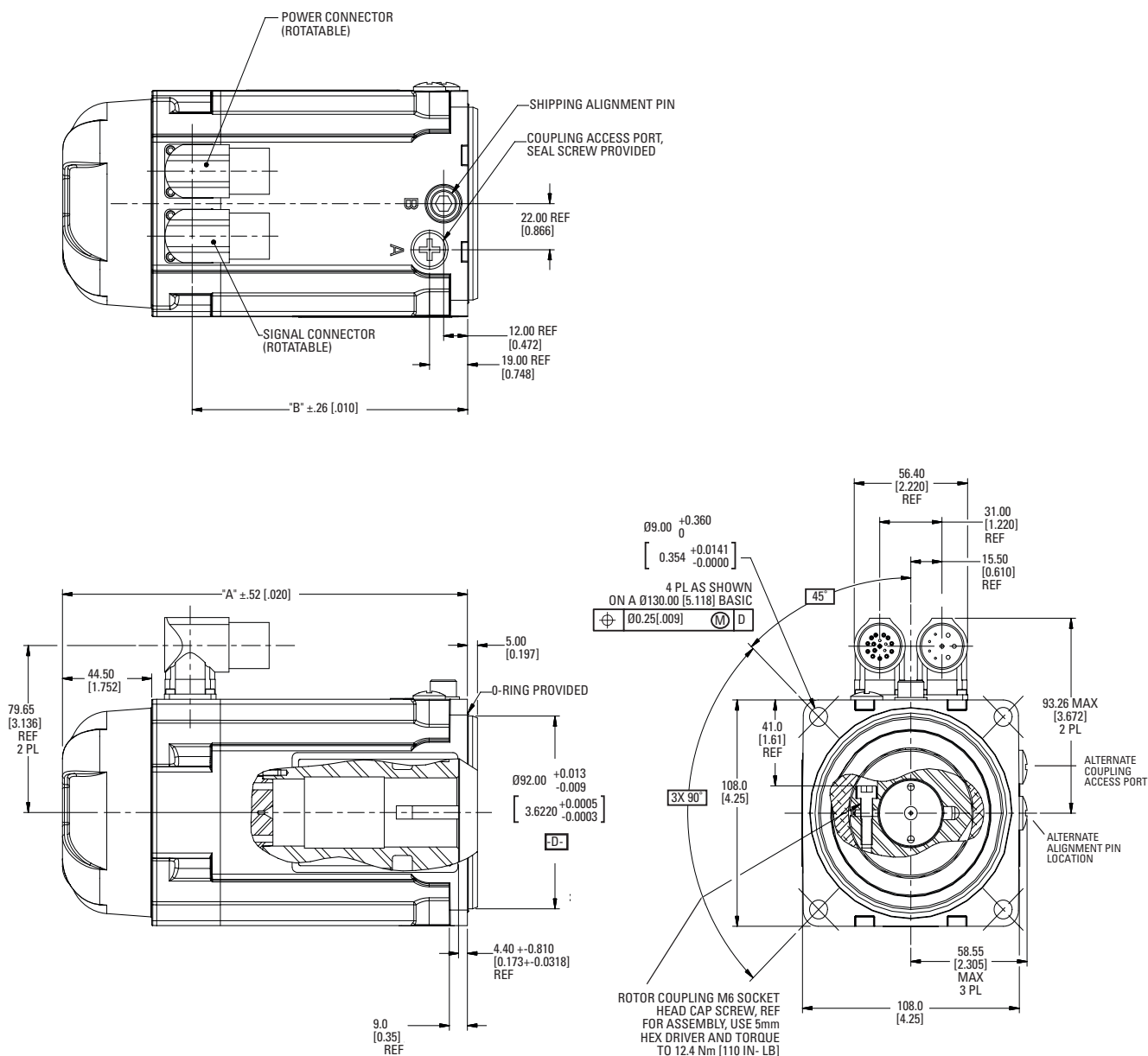

		C041	C042	C043	C044
Dim A	mm (inches)	171 (6.72)	202 (7.94)	233 (9.16)	264 (10.4)
Dim B	mm (inches)	107 (4.22)	138 (5.44)	169 (6.66)	200 (7.88)

For machine interface detail, see page 40

Outline Drawings

C(H)05x

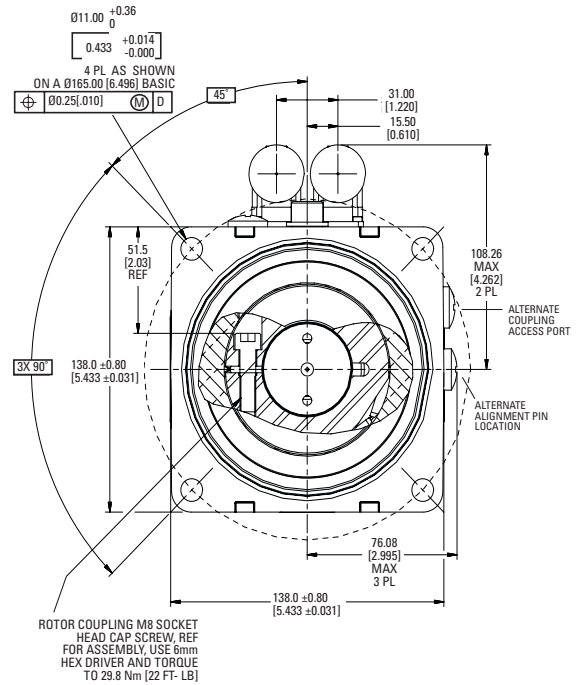
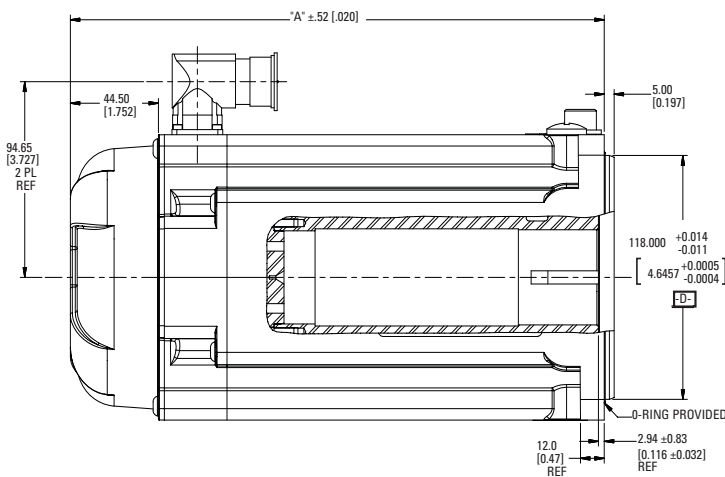
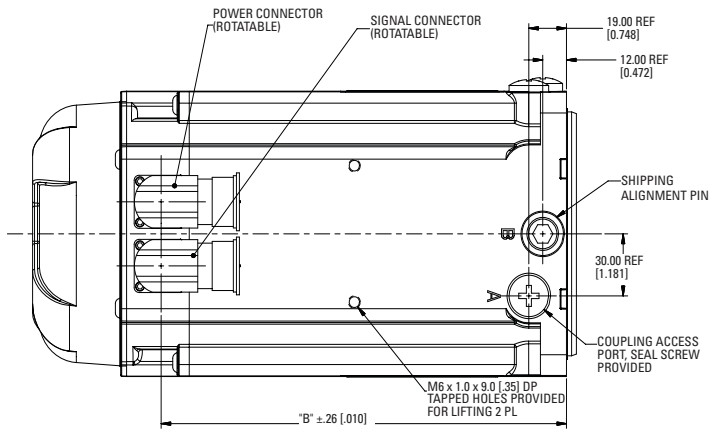

		C051	C052	C053	C054
Dim A	mm (inches)	195 (7.67)	220 (8.65)	245 (9.63)	270 (10.6)
Dim B	mm (inches)	131 (5.14)	156 (6.12)	181 (7.11)	206 (8.09)

For machine interface detail, see page 40

C(H)06x

C A R T R I D G E D D R M O T O R O U T L I N E D R A W I N G S

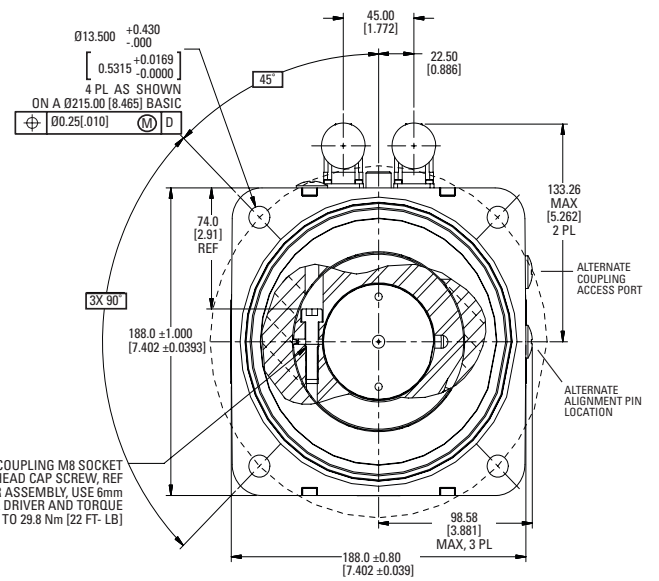
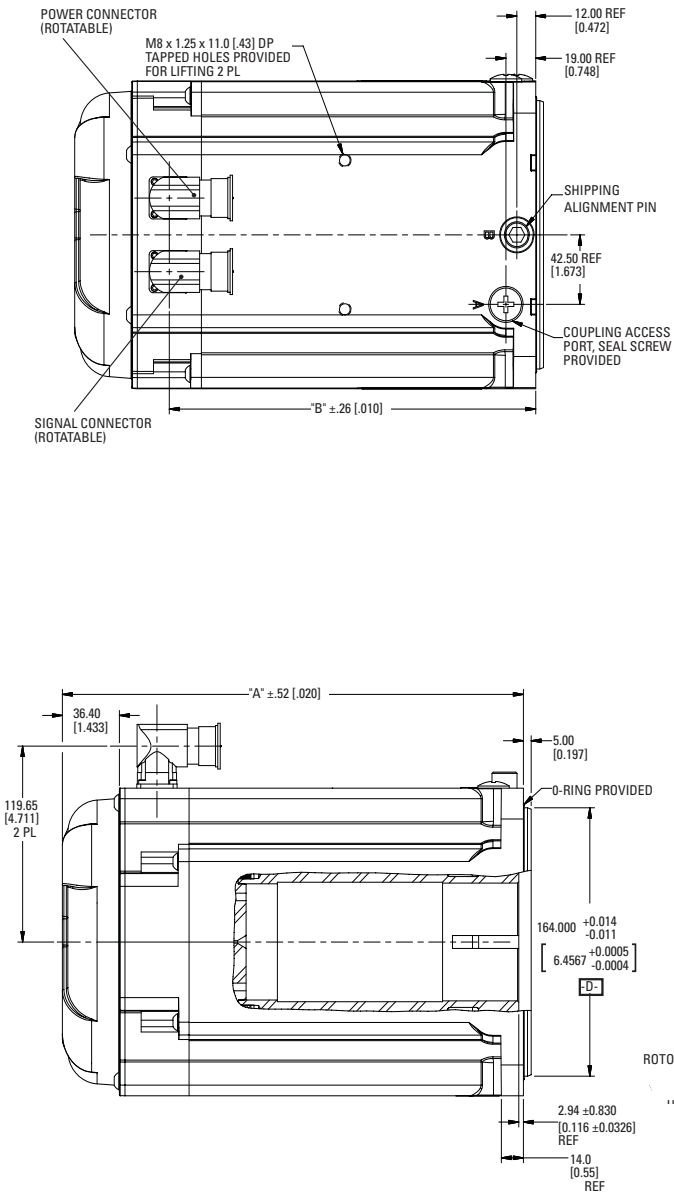

		C061	C062	C063
Dim A	mm (inches)	226 (8.90)	260 (10.2)	294 (11.6)
Dim B	mm (inches)	166 (6.52)	200 (7.86)	234 (9.20)

For machine interface detail, see page 40

Outline Drawings

C(H)09x without Through Bore

CARTRIDGE DDM MOTOR

OUTLINE DRAWINGS

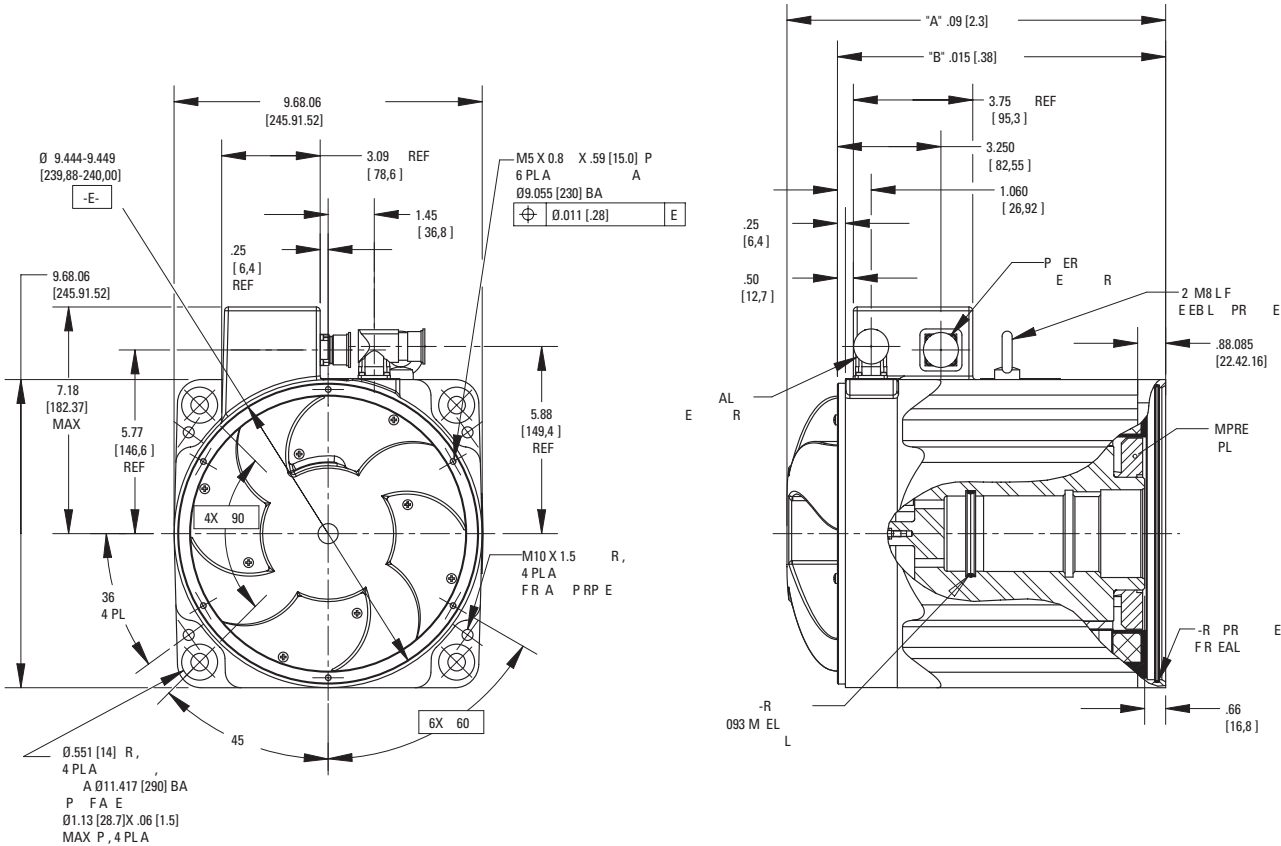

REAR CONNECTOR OPTION

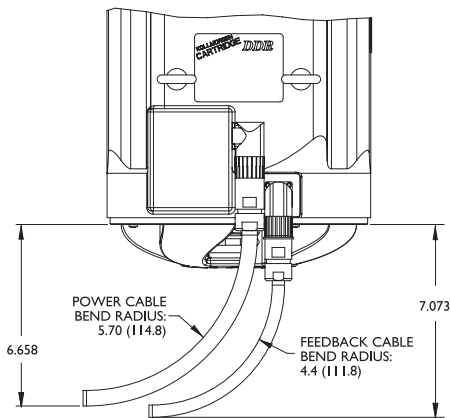

SIDE CONNECTOR OPTION

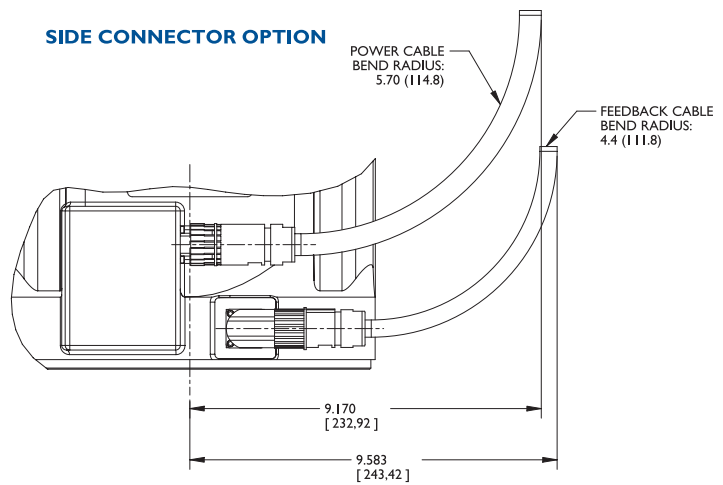

		C(H)091	C(H)092	C(H)093
Dim A	mm	204	253	302
	(inches)	(7.99)	(9.94)	(11.9)
Dim B	mm	163	212	262
	(inches)	(6.40)	(8.36)	(10.3)

For machine interface detail, see page 41

Outline Drawings

C(H)13X without Through Bore

CARTRIDGE MOTOR

OUTLINE DRAWINGS

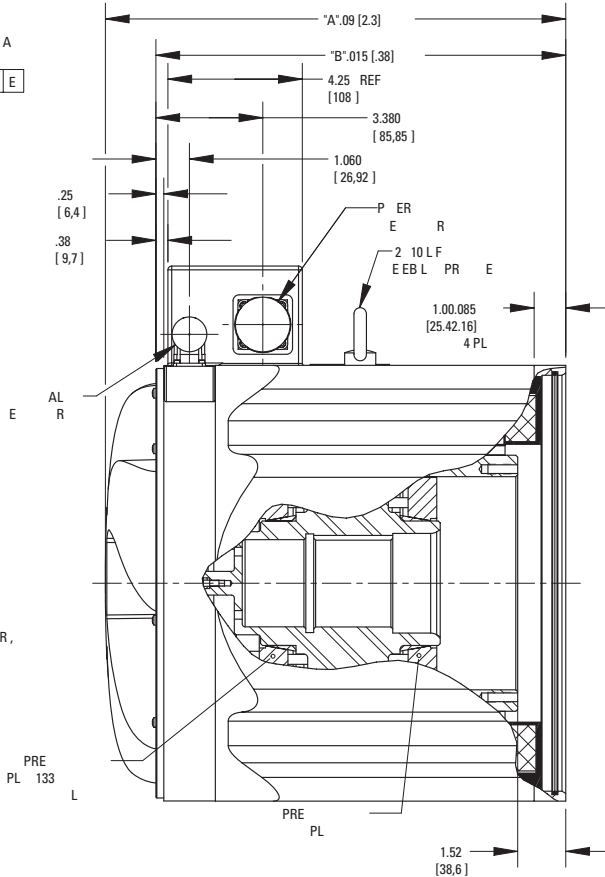
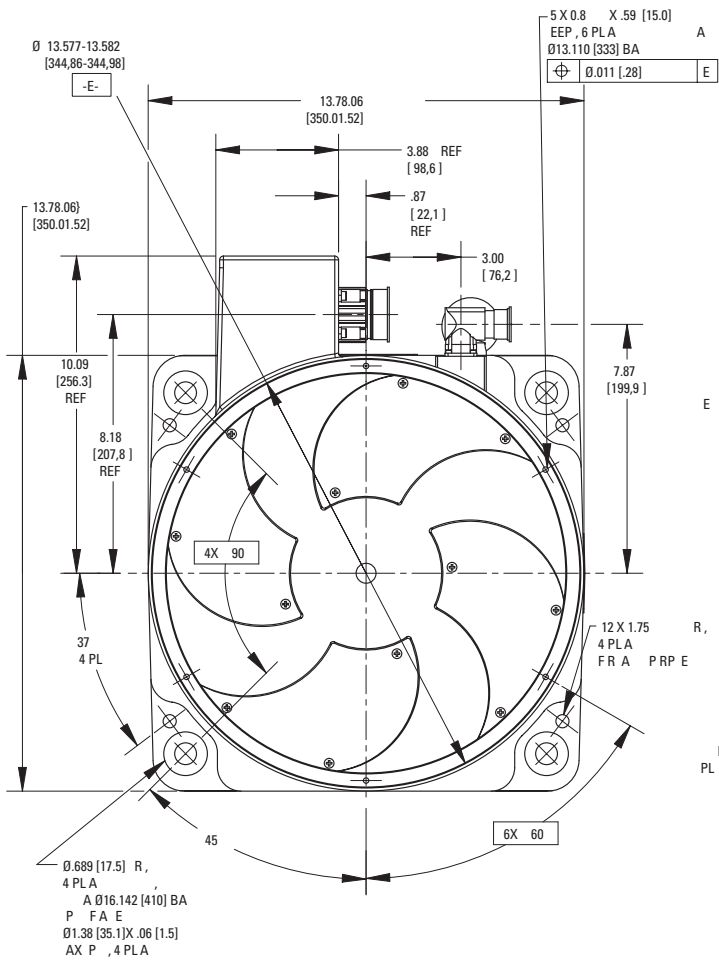

SIDE CONNECTOR OPTION

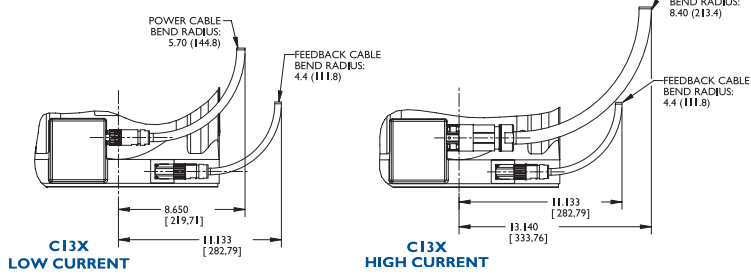

REAR CONNECTOR OPTION

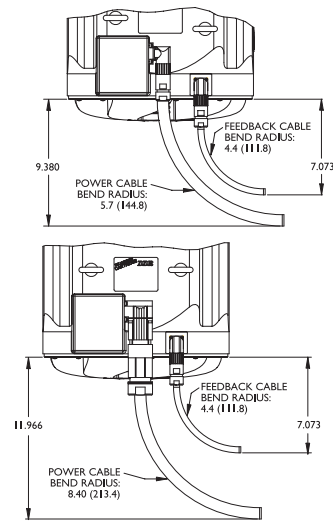

		C(H)131	C(H)132	C(H)133
Dim A	mm (inches)	231 (9.11)	301 (11.8)	370 (14.6)
Dim B	mm (inches)	191 (7.52)	260 (10.2)	329 (13.0)

For machine interface detail, see page 41

C(H)13x with Through Bore

CARTRIDGE DDR MOTOR
OUTLINE DRAWINGS

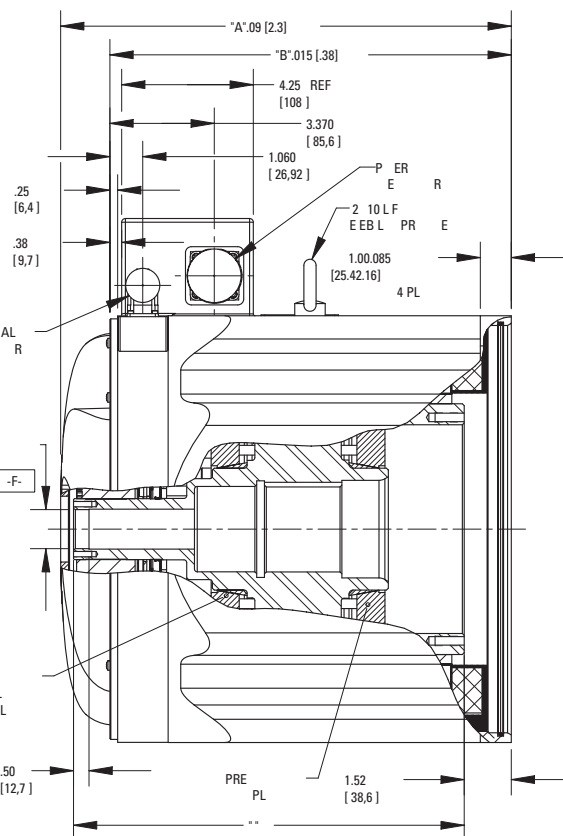
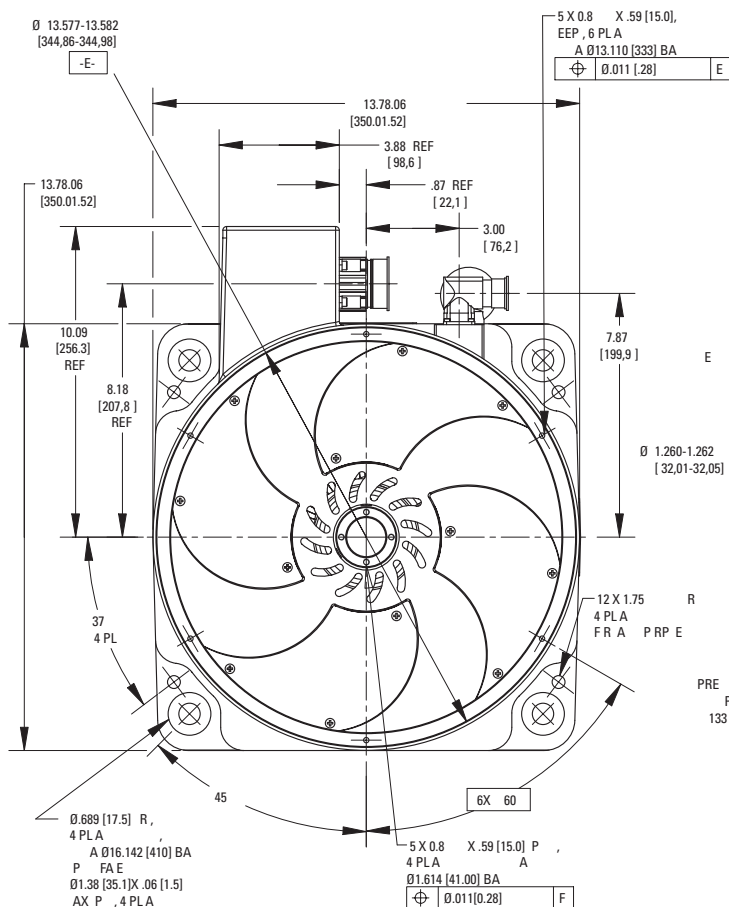

SIDE CONNECTOR OPTION

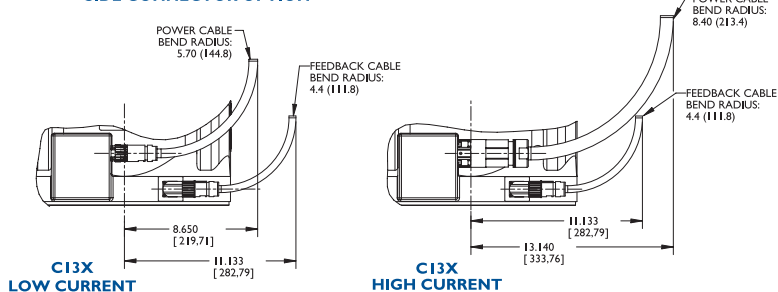

REAR CONNECTOR OPTION

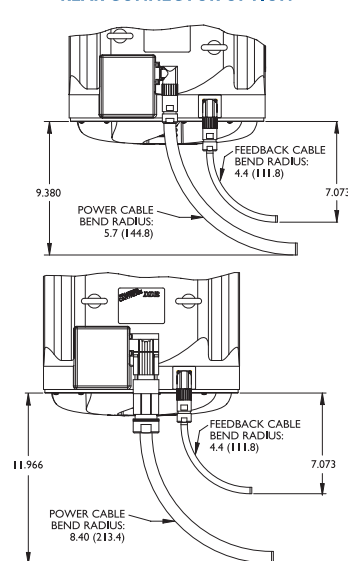

		C(H)131	C(H)132	C(H)133
Dim A	mm (inches)	231 (9.11)	301 (11.8)	370 (14.6)
Dim B	mm (inches)	191 (7.52)	260 (10.2)	329 (13.0)
Dim C	mm (inches)	182 (7.18)	251 (9.90)	320 (12.6)

For machine interface detail, see page 41

Mounting Requirements

Machine Mounting Requirements for C(H)04x, C(H)05x and C(H)06x

This drawing details the machine interface configuration for mounting the C04, C05, and C06 Cartridge DDR motors. It is important to maintain specified tolerance, concentricity and run out to ensure proper operation and longevity of the Cartridge DDR motor.

Axial Shaft Movement

During operation, the shaft which the Cartridge DDR motor is mounted to shall not move axially more than +/- 0.13 mm (0.005 inch).

Shaft Material

The shaft material can be steel or stainless steel.

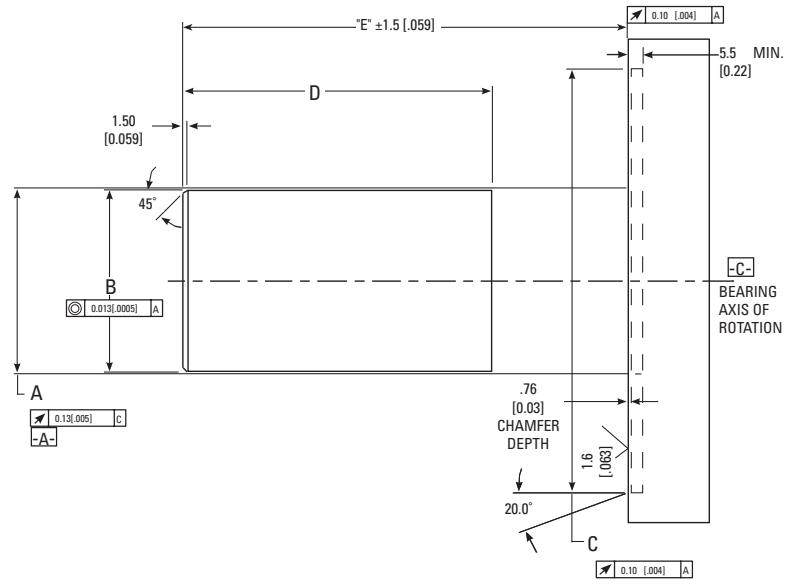

Machine Dimensions

Model	Dimensions									
	A		B		C		D		E	
	Min.	Max.	Min.	Max.	Min.	Max.	Min.	Max.	Min.	Max.
C(H)041	32.985	33.000	31.985	32.000	92.040	92.090	16.6	17.4	59.8	62.8
	(1.2987	- 1.2992)	(1.2593	- 1.2598)	(3.6237	- 3.6255)	(0.655	- 0.685)	(2.351	- 2.469)
C(H)042	32.985	33.000	31.985	32.000	92.040	92.090	47.6	48.4	90.8	93.8
	(1.2987	- 1.2992)	(1.2593	- 1.2598)	(3.6237	- 3.6255)	(1.875	- 1.905)	(3.571	- 3.689)
C(H)043	32.985	33.000	31.985	32.000	92.040	92.090	78.6	79.4	121.8	124.8
	(1.2987	- 1.2992)	(1.2593	- 1.2598)	(3.6237	- 3.6255)	(3.095	- 3.125)	(4.791	- 4.909)
C(H)044	32.985	33.000	31.985	32.000	92.040	92.090	109.6	110.4	152.8	155.8
	(1.2987	- 1.2992)	(1.2593	- 1.2598)	(3.6237	- 3.6255)	(4.315	- 4.345)	(6.011	- 6.129)
C(H)051	45.985	46.000	44.985	45.000	118.040	118.090	34.6	35.4	80.5	83.5
	(1.8105	- 1.8110)	(1.7712	- 1.7717)	(4.6473	- 4.6492)	(1.365	- 1.395)	(3.171	- 3.289)
C(H)052	45.985	46.000	44.985	45.000	118.040	118.090	59.6	60.4	105.5	108.5
	(1.8105	- 1.8110)	(1.7712	- 1.7717)	(4.6473	- 4.6492)	(2.345	- 2.375)	(4.151	- 4.269)
C(H)053	45.985	46.000	44.985	45.000	118.040	118.090	84.6	85.4	130.5	133.5
	(1.8105	- 1.8110)	(1.7712	- 1.7717)	(4.6473	- 4.6492)	(3.335	- 3.365)	(5.141	- 5.259)
C(H)054	45.985	46.000	44.985	45.000	118.040	118.090	109.6	110.4	155.5	158.5
	(1.8105	- 1.8110)	(1.7712	- 1.7717)	(4.6473	- 4.6492)	(4.315	- 4.345)	(6.121	- 6.239)
C(H)061	71.985	72.000	70.985	71.000	164.040	164.090	48.6	49.4	102.5	105.5
	(2.8341	- 2.8346)	(2.7948	- 2.7953)	(6.4583	- 6.4602)	(1.915	- 1.945)	(4.031	- 4.149)
C(H)062	71.985	72.000	70.985	71.000	164.040	164.090	82.6	83.4	136.5	139.5
	(2.8341	- 2.8346)	(2.7948	- 2.7953)	(6.4583	- 6.4602)	(3.255	- 3.285)	(5.371	- 5.489)
C(H)063	71.985	72.000	70.985	71.000	164.040	164.090	116.6	117.4	170.5	173.5
	(2.8341	- 2.8346)	(2.7948	- 2.7953)	(6.4583	- 6.4602)	(4.595	- 4.625)	(6.711	- 6.829)

Dimensions are in millimeters (inches)

Machine Mounting Requirements for C(H)09x and C(H)13x

These drawings detail the machine interface configuration for mounting the Cartridge DDR motor. It is important to maintain specified tolerance, concentricity, and run out to ensure proper operation and longevity of the Cartridge DDR motor.

Axial Shaft Movement

Note there is a static and dynamic call out for axial length. The static tolerance is the allowable variance of the shaft before the motor is mounted. The dynamic tolerance is the allowable movement of the shaft after the motor is mounted and during operation.

Shaft Material

The shaft material must have a minimum yield strength of 55,000 PSI. This suggests the material shall be cold rolled steel with a minimum 0.30% carbon content.

Shaft Key

The C09x and C13x Cartridge DDR motors are provided with a key. If the materials and dimensions on this page and the compression coupling torque procedure are strictly followed, then the key is not needed. The key is provided as a safety precaution to avoid severe damage to the Cartridge DDR motor and to the machine it is mounted to that can result if the compression coupling is not properly engaged during operation. No key is used on the C04x, C05x and C06x.

Heat Dissipation

The Cartridge DDR motor is a source of heat connected directly to the machine frame. For applications which are sensitive to heat generation, the continuous torque rating of the Cartridge DDR must be reduced. To facilitate heat sensitive applications, Cartridge DDR motors have dual continuous torque ratings, 110°C rise for maximum capacity and 80°C rise for de-rated capacity.

C(H)09x

		C(H)091	C(H)092	C(H)093
Dim A	inches	1.730	3.470	4.910
Dim B	inches	.38	.94	1.00
Dim C	inches	3.540	5.280	6.720

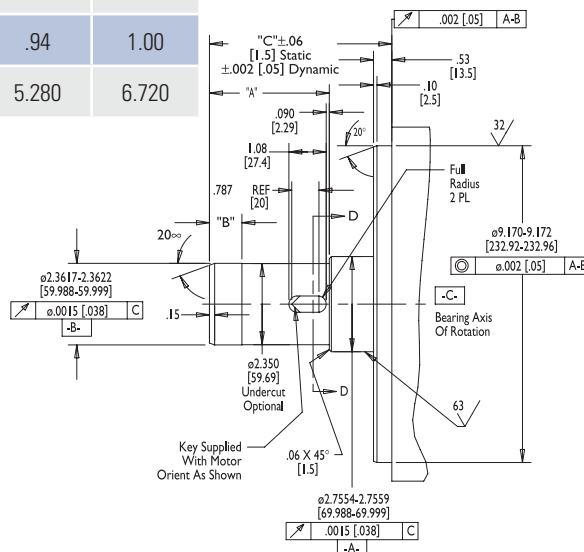
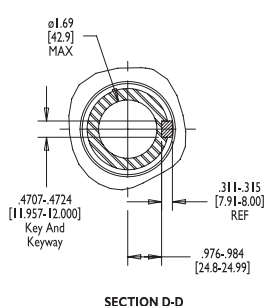

C(H)13x

		C(H)131	C(H)132	C(H)133
Dim A	inches	.37	.75	1.6
Dim B	inches	1.590	3.300	4.670
Dim C	inches	1.08	1.71	2.26
Dim D	inches	4.490	6.610	9.980

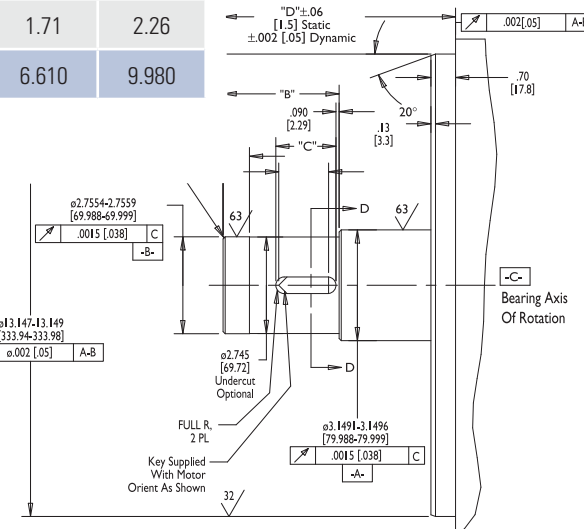
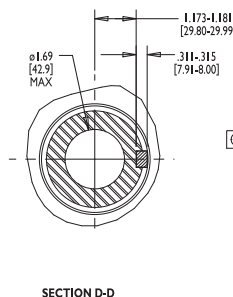

Model Nomenclature

MODEL NOMENCLATURE

Cartridge DDR Motor

C 09 1 A - 1 1 - 1 1 0 5 S - xxx

Product Family
 C = 230 Volt
 CH = 400/480 Volt

Frame Size Field
 04 = 4.25" Sq. Housing
 05 = 5.43" Sq. Housing
 06 = 7.40" Sq. Housing
 09 = 9.68" Sq. Housing
 13 = 13.78" Sq. Housing

Stack Length Field
 1 = Short Stack
 2 = Mid Stack
 3 = Long Stack
 4 = Extra Long Stack
 (04 and 05 frame sizes only)

Winding Letter Field
 A = Standard Winding
 B = High-Speed Winding (C04x, C05x, C06x, C13x)
 C = Standard Winding (C052, C062, C063, C092, C093, C13x)
 D = High-Speed Winding (C052 only)

Mounting Option Field
 1 = Std. Flange Mount

Connector Option Field
 1 = Side Connector Option (09 and 13 frame sizes only)
 2 = Rear Connector Option (09 and 13 frame sizes only)
 3 = 90° Rotatable Connectors (04, 05 and 06 frame sizes only)

Sequential number for specials
 (Unique description within a frame size)

Agency Certification Option Field
 Blank = UL/CE Certification
 S = Non-UL

Unit Seal Option Field
 5 = Sealed
 (Shaft Option "1" - IP64 Rating when customer seals interface side)
 (Shaft Option "2" or "3" - IP65 Rating when customer seals interface side)

Bearing Option Field
 0 = No Bearing Design
 (Standard - Integral Shipping Clamp Provided)

Feedback Option Field
 1 = EnDat single turn absolute sine encoder (2048 line)
 3 = BiSS single turn absolute sine encoder (2048 line)
 4 = BiSS multi-turn absolute sine encoder (2048 line)
 5 = EnDat Multi-turn absolute sine encoder (2048 line)

Shaft Field
 1 = Hollow with Compression Coupling and Key
 (09 and 13 frame sizes only)
 2 = Solid with Compression Coupling and Key
 (09 and 13 frame sizes only)
 3 = Solid with Split Ring Coupling and no Key
 (04, 05, and 06 frame sizes only)

Note: Options shown in bold blue text are considered standard.

AKD Servo Drive

AKD – B 003 06 – NB AN – 0000

AKD Series

Version

B = Base drive

- C = Central power supply for AKD-N (Requires CB Extention)
- N = Decentralized drive (Requires DB, DF, or DS Extention)
- P = Position indexer (motion tasking)
- T = AKD BASIC Language Programmable drive (Requires IC or NB Extention)
- M = Multi-axis Master Drive (Requires MC Extention option, and EC Connectivity option)

Current Rating

- 003 = 3 Amp
- 006 = 6 Amp
- 010 = 10kW (With Version C, this field refers to power.)
- 012 = 12 Amp
- 024 = 24 Amp

Voltage

- 06 = 120/240 Vac 1Ø/3Ø (24 Amp Drive: 240 Vac 3Ø only)
- 07 = 240/480 Vac 3Ø (Version C: 07 = 400/480 Vac 3Ø | Version N: 07 = 560/680 Vdc)

Variants

0000 = Standard

Connectivity*

AN = Analog command

- CC = CANopen OR EtherCAT
- CN = CANopen
- EC = EtherCAT
- EI = EtherNet/IP
- PN - PROFINET
- SQ = SynqNet

Drive Version Availability

- B, P, T
- P
- P
- C, M, N, P
- P
- P
- B

*Motion Tasking is included as a free upgrade with CC, CN, EC, EI and PN

Extension

- CB = without extention
- DB = hybrid motor cable
- DF = additional EtherCAT port + feedback connector
- DS = local STO + feedback connector
- IC = Expanded I/O version and SD card slot ("T" version drive only)

NB = Without extensions

Note: Options shown in bold blue text are considered standard.

Model Nomenclature

S700 Servo Drive

MODEL NOMENCLATURE

S7 48 0 2 – NA – NA – NA

S700 Series

Current Rating

- 01 = 1.5 Arms
- 03 = 3 Arms
- 06 = 6 Arms
- 12 = 12 Arms
- 24 = 24 Arms
- 48 = 48 Arms
- 72 = 72 Arms

Voltage Rating

0 = 208...480 Vac

6 = 110...230 Vac (with 1.5 to 24 Arms only)

Electrical Options

2 = Standard

Expansion Card Slot 3

**NA = No Expansion card in Slot 3
EtherCAT and CANopen on board**

- F2 = Fan controller
- PM = Post/O
- PA = Post/O-Monitor
- S1 = Safety card SIL 3
- S2 = Safety card SIL 2

Expansion Card Slot 2

**NA = No Expansion card in Slot 2
EtherCAT and CANopen on board**

- F2 = Fan controller
- PM = Post/O
- PA = Post/O-Monitor

Expansion card F2 in Slot 2 can be used combined with a card in Slot 1.

Expansion Card Slot 1

**NA = No expansion card in Slot 1,
EtherCAT and CANopen on board**

- DN = DEVICENET
- PB = PROFIBUS
- SE = SERCOS
- SN = SYNQNET
- EI = I/O extension

Expansion card F2 in Slot 2 can be used combined with a card in Slot 1.

Note: Options shown in bold blue text are considered standard.

MOTIONEERING® Application Engine

To help select and size Kollmorgen components, this Windows®-based motor-sizing program takes a systems approach to the selection of brushless DC servomotors, stepper motors and drives. MOTIONEERING application engine, available at www.kollmorgen.com, uses a project concept for the collection and saving of rotary and linear multi-axis load information. This provides the user the flexibility to sum the effects of multiple axes of motion for power supply and shunt regeneration sizing.

A wide variety of linear and rotary mechanisms are provided including lead screw, rack and pinion, conveyor, nip rolls, cylinder, rotary, and direct data-entry using unique sizing algorithms and product databases criteria.

The searchable database consists of hundreds of systems on product combinations including rotary housed and frameless brushless servomotors, direct drive rotary and linear brushless servomotors, linear actuators (electric cylinders, rodless actuators, and precision tables) and stepper systems.

The MOTIONEERING application engine also provides versatile units-of-measure selection options for mechanism and motion profile data-entry, with the ability to convert data into other available units. Online Help explains program functions and the definition of terms and equations used in the program.

Features

- Group multiple mechanisms within a “project” – organize and combine data for power supply and regeneration sizing
- Types of mechanisms for analysis include lead screw, rack and pinion, conveyor, nip rolls, rotary and direct drive linear motor
- Motion profile options include simple triangle, 1/3-1/3-1/3 trapezoidal, variable traverse trapezoidal, and more
- Search results display shows color highlighted solution set of options for easy evaluation of system specifications and selection

Supported Operating Systems

- Microsoft® Windows 2000, XP, Vista, Windows 7

MOTIONEERING 6.4.0 includes

- **NEW** AKMH series Stainless Steel Motors and AKD systems at 120, 240, 400 and 480 V
 - Designed to meet IP69K, EHEDG, 3A, and built with FDA approved food grade materials
 - 19 frame/stack length combinations
 - Continuous torque to 22 Nm
 - Peak torque to 92 Nm
- Corrected length dimensions of some AKM servomotor & gearmotor models
- Corrected CH132 thermal resistance
- Added HIPERFACE DSL sine encoder to search field

Note: Performance curves included for all servomotor systems



About Kollmorgen

Kollmorgen is a leading provider of motion systems and components for machine builders. Through world-class knowledge in motion, industry-leading quality and deep expertise in linking and integrating standard and custom products, Kollmorgen delivers breakthrough solutions that are unmatched in performance, reliability and ease-of-use, giving machine builders an irrefutable marketplace advantage.

For assistance with your application needs in North America, contact us at: 540-633-3545, support@kollmorgen.com or visit www.kollmorgen.com for a global contact list.

- Application Centers
- Global Design & Manufacturing
- Global Manufacturing



KOLLMORGEN®

Because Motion Matters™

Kollmorgen
 203A West Rock Road
 Radford, VA 24141 USA
 Phone: 1-540-633-3545
 Fax: 1-540-639-4162

Kollmorgen Europe GmbH
 Pempelfurtstraße 1
 40880 Ratingen
 Germany
 Phone: +49 (0) 2102 9394 0
 Fax: +49 (0) 2102 9394 3155

Kollmorgen Asia
 China
 Rm 2205, Scitech Tower
 22 Jianguomen Wai Street
 Phone: +86 400 666 1802
 Fax: +86 10 6515 0263

Kollmorgen Aerospace and Defense
 501 West Main Street
 Radford, VA 24141 USA
 Phone: 1-540-731-5668
 Fax: 1-540-731-5679